

REVISIONS				
ECO NO	REV	DESCRIPTION	ENG DATE	APRV
	A			

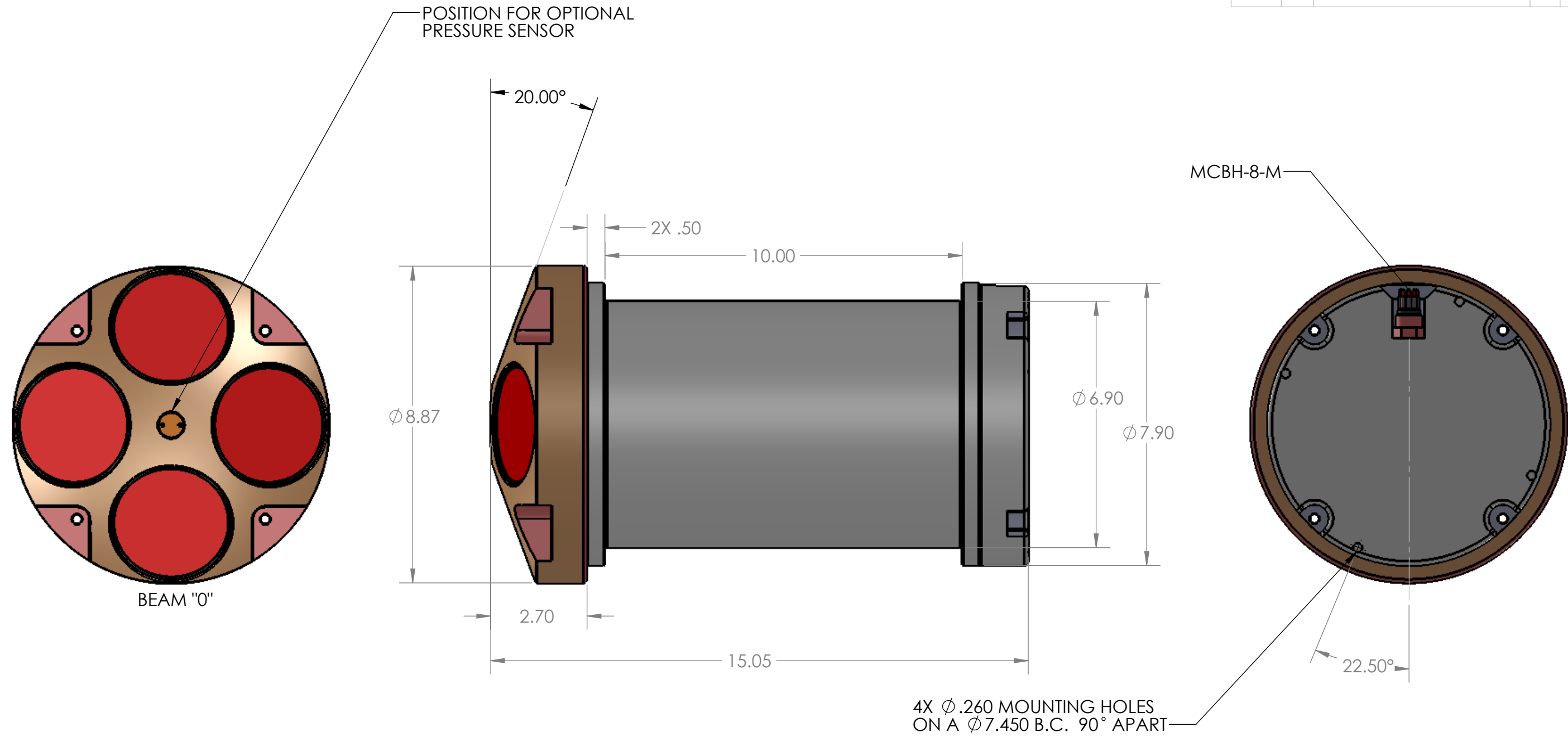

NOTES:

1. HOUSING MATERIAL: ACETAL PLASTIC
2. SINGLE 440 W/HR C CELL BATTERY PACK
3. PRESSURE RATING: 300M
4. WEIGHT IN AIR: 27 LBS
5. WEIGHT IN WATER: 3 LBS

PROPRIETARY AND CONFIDENTIAL
 THE INFORMATION CONTAINED IN THIS DRAWING IS THE SOLE PROPERTY OF Rowe Technologies Inc.. ANY REPRODUCTION IN PART OR AS A WHOLE WITHOUT THE WRITTEN PERMISSION OF Rowe Technologies Inc. IS PROHIBITED.

		UNLESS OTHERWISE SPECIFIED:		NAME		DATE		Rowe Technologies Inc. Poway CA, 92064	
		DIMENSIONS ARE IN INCHES		DRAWN				TITLE:	
		TOLERANCES:		CHECKED				OUTLINE DRAWING, SC DP600	
		FRACTIONAL ±		ENG APPR.				SIZE DWG. NO. REV	
		ANGULAR: MACH ± BEND ±		MFG APPR.				B 10222 A	
		TWO PLACE DECIMAL ± .005		Q.A.				SCALE: 1:4 SHEET 1 OF 1	
		THREE PLACE DECIMAL ± .002		COMMENTS:					
		INTERPRET GEOMETRIC TOLERANCING PER:							
		MATERIAL							
NEXT ASSY		USED ON		FINISH					
APPLICATION				DO NOT SCALE DRAWING					

REVISIONS				
ECO NO	REV	DESCRIPTION	ENG DATE	APRV
	A			

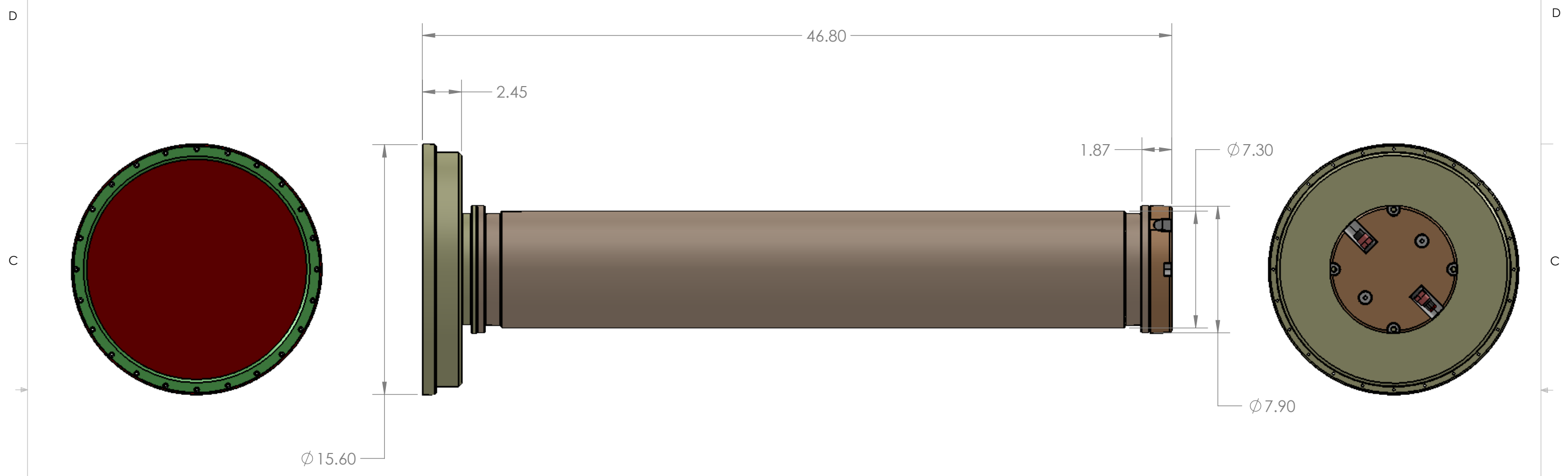

WEIGHT IN AIR: 123 LBS
 WEIGHT IN WATER: 45 LBS

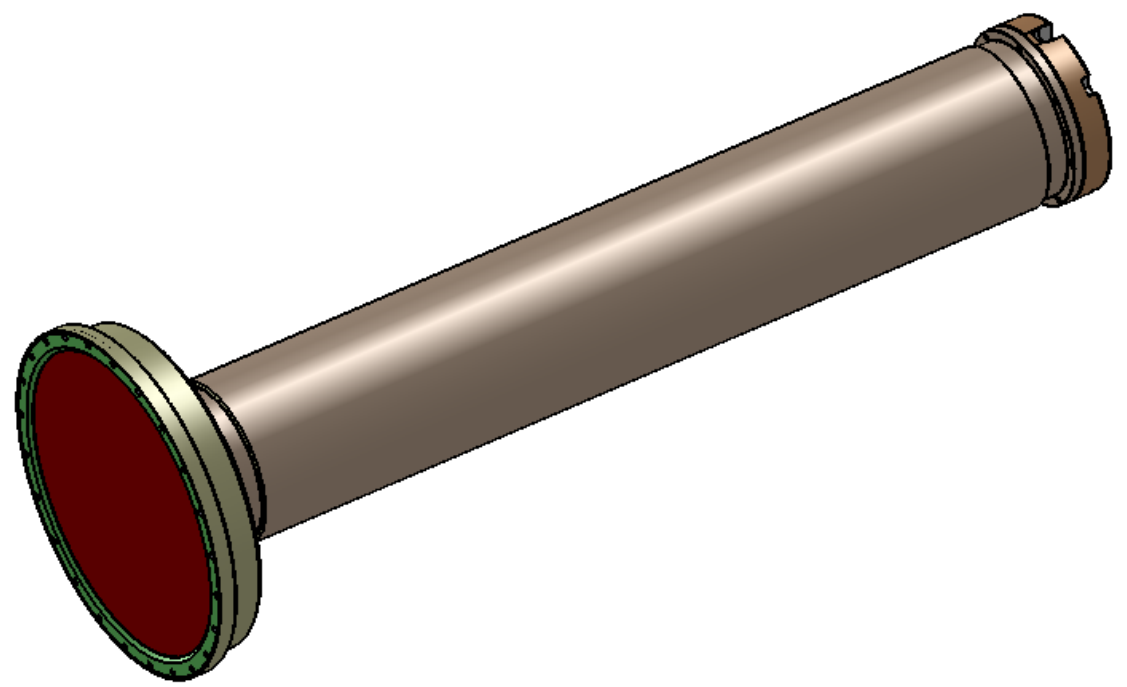

PROPRIETARY AND CONFIDENTIAL
 THE INFORMATION CONTAINED IN THIS DRAWING IS THE SOLE PROPERTY OF Rowe Technologies Inc.. ANY REPRODUCTION IN PART OR AS A WHOLE WITHOUT THE WRITTEN PERMISSION OF Rowe Technologies Inc. IS PROHIBITED.

		UNLESS OTHERWISE SPECIFIED:				Rowe Technologies Inc. Poway CA, 92064	
		DIMENSIONS ARE IN INCHES		DRAWN		TITLE:	
		TOLERANCES:		CHECKED		78 DA, SELF CONTAINED OUTLINE DWG, 5 BAT PACK 1500M	
		FRACTIONAL \pm		ENG APPR.		SIZE	
		ANGULAR: MACH \pm BEND \pm		MFG APPR.		DWG. NO.	
		TWO PLACE DECIMAL $\pm .005$		Q.A.		10371	
		THREE PLACE DECIMAL $\pm .002$		COMMENTS:		REV	
		INTERPRET GEOMETRIC TOLERANCING PER:				A	
		MATERIAL				SCALE: 1:12	
		AL ALY 6061-T6				SHEET 1 OF 1	
		FINISH					
NEXT ASSY	USED ON	DO NOT SCALE DRAWING					
APPLICATION							

REVISIONS

ECO NO	REV	DESCRIPTION	ENG DATE	APRV

D
C
B
A

D
C
B
A

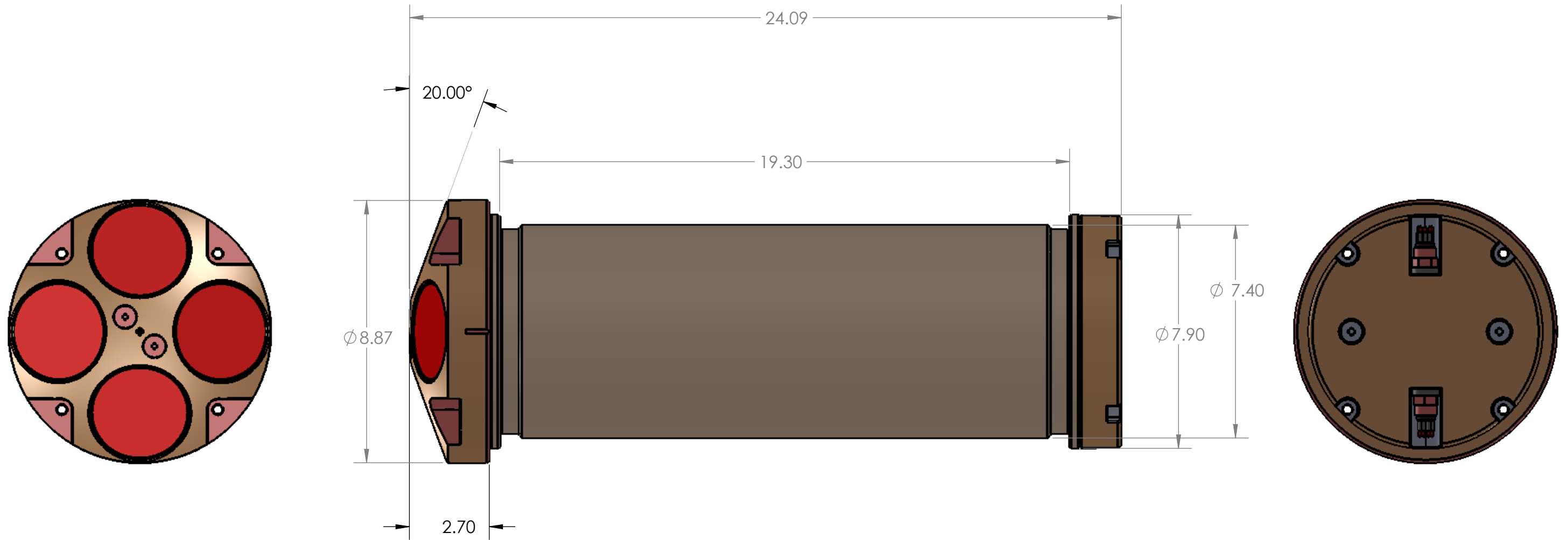

NOTES:

1. MATERIAL: 6061-T6 AL ALY
2. WEIGHT IN AIR: 75 LBS, WEIGHT IN WATER: 34 LBS (WITH BATTERIES)

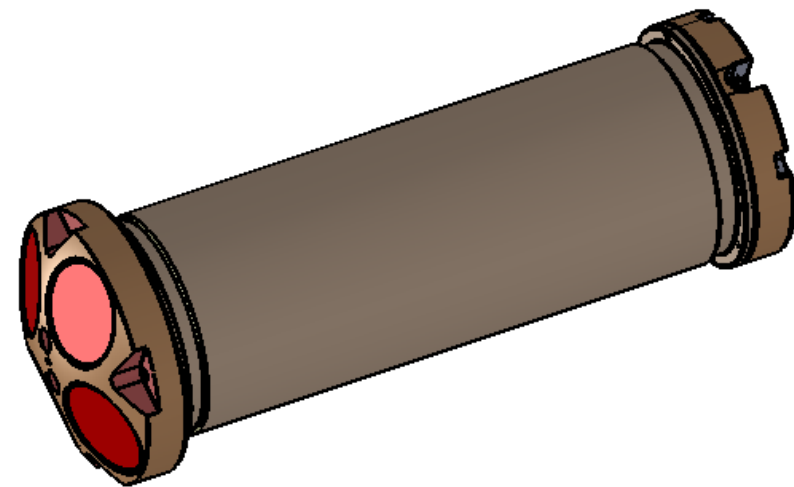

PROPRIETARY AND CONFIDENTIAL
 THE INFORMATION CONTAINED IN THIS DRAWING IS THE SOLE PROPERTY OF Rowe Technologies Inc.. ANY REPRODUCTION IN PART OR AS A WHOLE WITHOUT THE WRITTEN PERMISSION OF Rowe Technologies Inc. IS PROHIBITED.

UNLESS OTHERWISE SPECIFIED:		NAME	DATE	Rowe Technologies Inc. Poway CA, 92064	
DIMENSIONS ARE IN INCHES		DRAWN		TITLE: OUTLINE DWG, 300 /600 3000M SC	
TOLERANCES:		CHECKED			
FRACTIONAL ±		ENG APPR.			
ANGULAR: MACH ± BEND ±		MFG APPR.			
TWO PLACE DECIMAL ± .005		Q.A.		SIZE DWG. NO. REV	
THREE PLACE DECIMAL ± .002		COMMENTS:		B 10338 A	
INTERPRET GEOMETRIC TOLERANCING PER:				SCALE: 1:8 SHEET 1 OF 1	
MATERIAL					
SEE NOTES					
FINISH					
NEXT ASSY	USED ON				
APPLICATION				DO NOT SCALE DRAWING	

8 7 6 5 4 3 2 1

REVISIONS				
ECO NO	REV	DESCRIPTION	ENG DATE	APRV
	A			

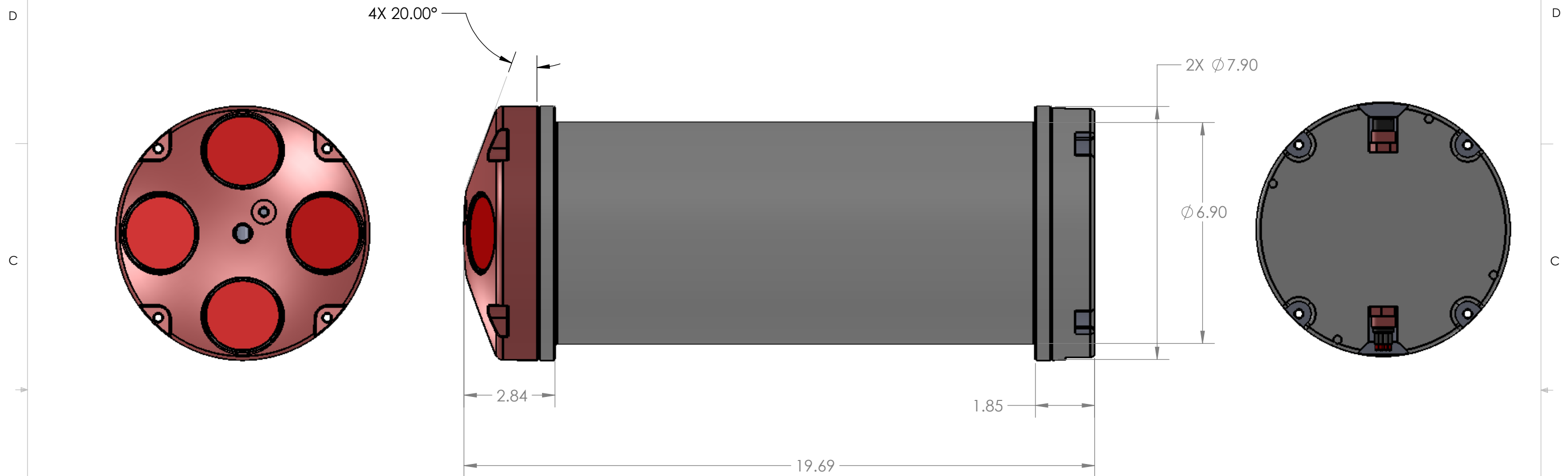

WEIGHT IN AIR: 38 LBS
 WEIGHT IN WATER: 8 LBS

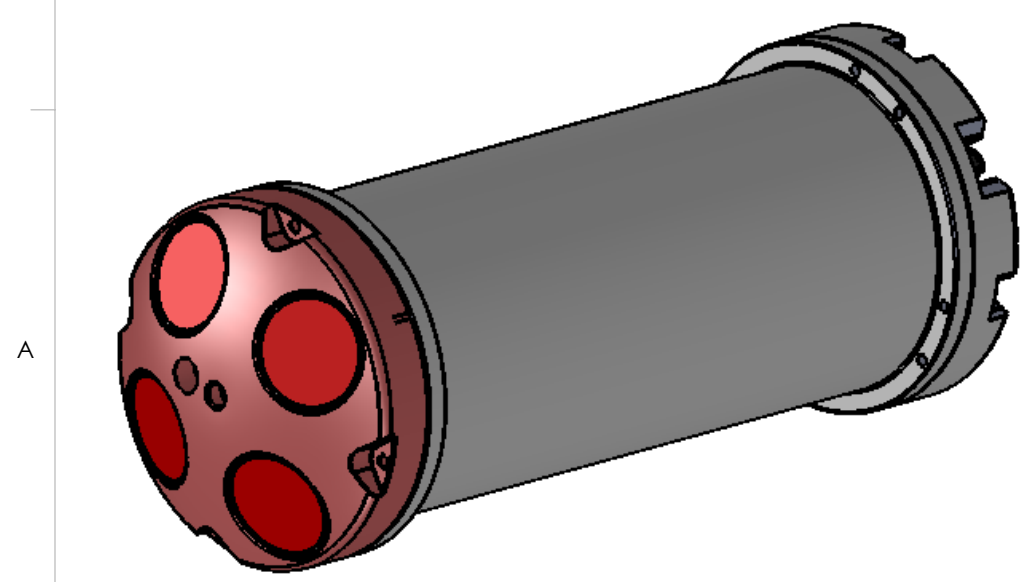

PROPRIETARY AND CONFIDENTIAL
 THE INFORMATION CONTAINED IN THIS DRAWING IS THE SOLE PROPERTY OF Rowe Technologies Inc.. ANY REPRODUCTION IN PART OR AS A WHOLE WITHOUT THE WRITTEN PERMISSION OF Rowe Technologies Inc. IS PROHIBITED.

		UNLESS OTHERWISE SPECIFIED:		NAME	DATE	Rowe Technologies Inc. Poway CA, 92064	
		DIMENSIONS ARE IN INCHES		DRAWN		TITLE: OUTLINE, 1200 SC COASTAL 2 BATTERY PACKS	
		TOLERANCES:		CHECKED			
		FRACTIONAL ±		ENG APPR.			
		ANGULAR: MACH ± BEND ±		MFG APPR.			
		TWO PLACE DECIMAL ± .005		Q.A.		SIZE DWG. NO. REV	
		THREE PLACE DECIMAL ± .002		COMMENTS:		B 10466 A	
		INTERPRET GEOMETRIC TOLERANCING PER:				SCALE: 1:8 SHEET 1 OF 1	
		MATERIAL ACETAL					
		FINISH					
NEXT ASSY	USED ON	DO NOT SCALE DRAWING					
APPLICATION							