

REVISIONS

ECO NO	REV	DESCRIPTION	ENG DATE	APRV

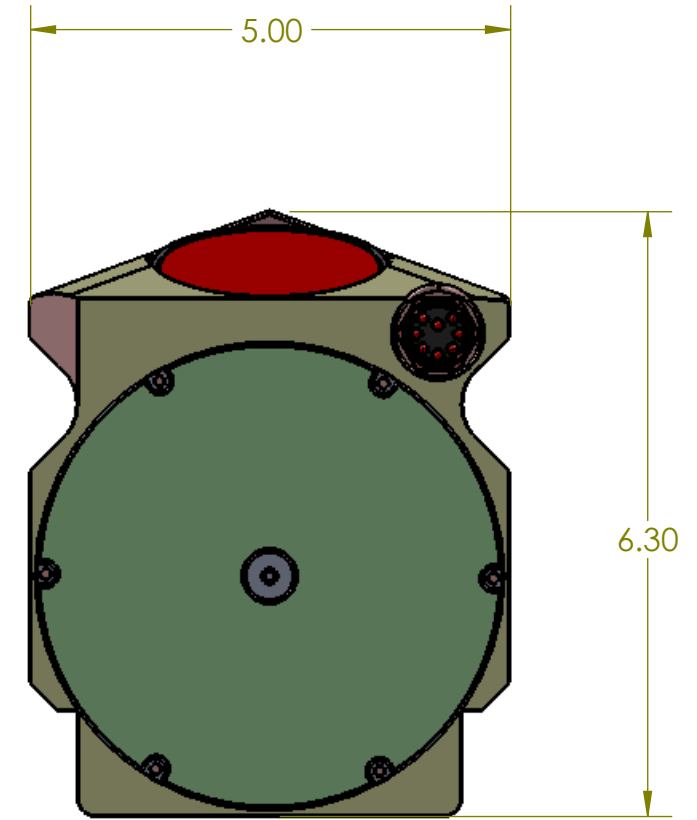

8.62

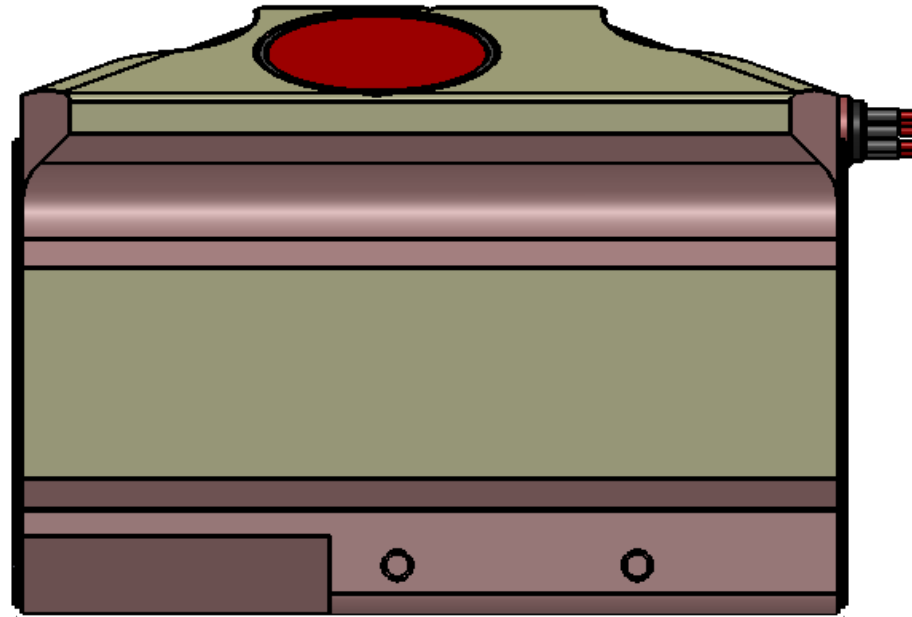
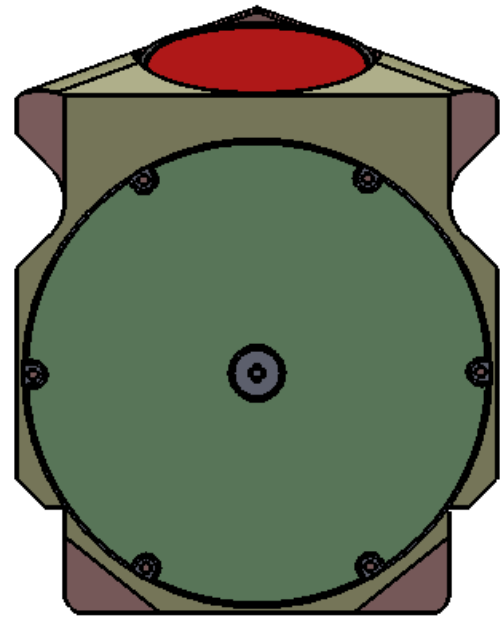
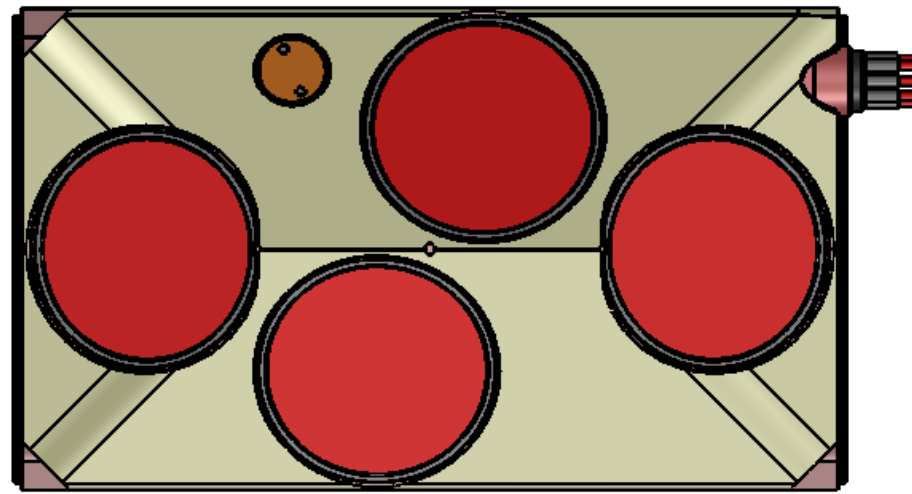
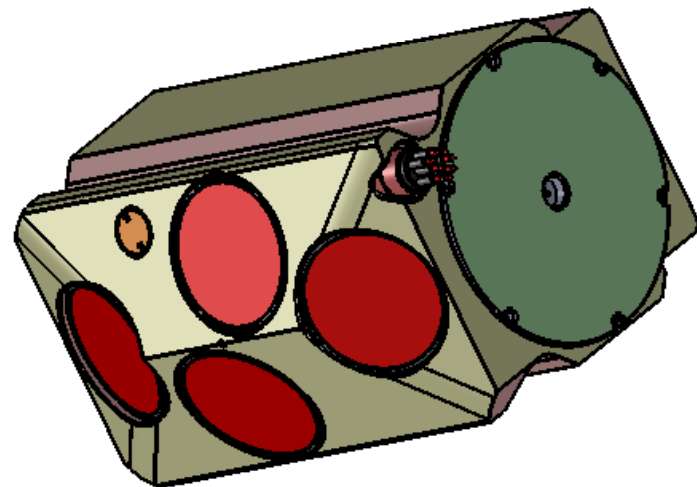

WEIGHT IN AIR: 10 lbs

PROPRIETARY AND CONFIDENTIAL
 THE INFORMATION CONTAINED IN THIS DRAWING IS THE SOLE PROPERTY OF Rowe Technologies Inc.. ANY REPRODUCTION IN PART OR AS A WHOLE WITHOUT THE WRITTEN PERMISSION OF Rowe Technologies Inc. IS PROHIBITED.

UNLESS OTHERWISE SPECIFIED:		NAME	DATE	Rowe Technologies Inc. Poway CA, 92064	
DIMENSIONS ARE IN INCHES		DRAWN		TITLE:	
TOLERANCES:		CHECKED		DVL, SINGLE HOUSING, 600/1200	
FRACTIONAL ±		ENG APPR.		SIZE	DWG. NO.
ANGULAR: MACH ± BEND ±		MFG APPR.		B	REV
TWO PLACE DECIMAL ± .005		Q.A.		SCALE: 1:4	SHEET 1 OF 1
THREE PLACE DECIMAL ± .002		COMMENTS:			
INTERPRET GEOMETRIC TOLERANCING PER:					
MATERIAL		ACETAL			
FINISH		DO NOT SCALE DRAWING			
NEXT ASSY	USED ON				
APPLICATION					

REVISIONS

ECO NO	REV	DESCRIPTION	ENG DATE	APRV

D

C

B

A

D

C

B

A

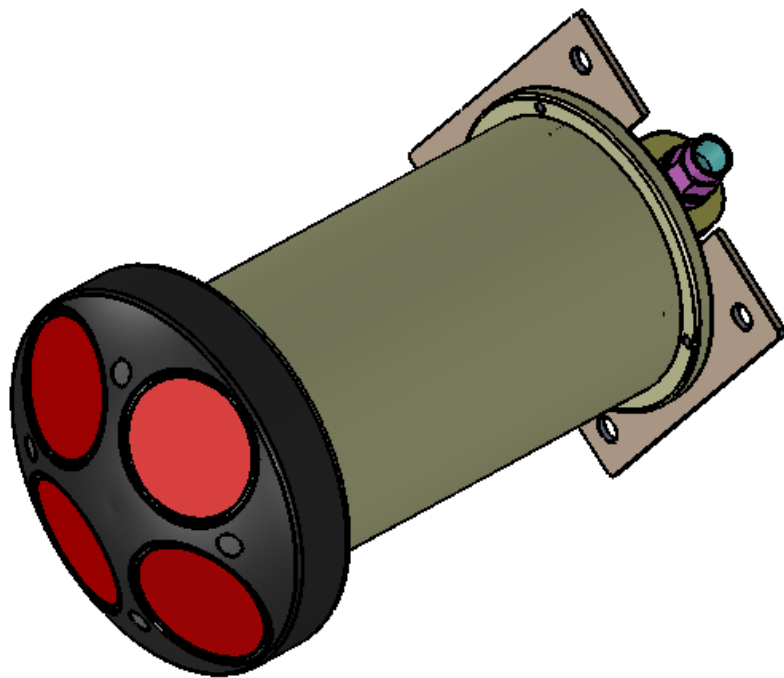
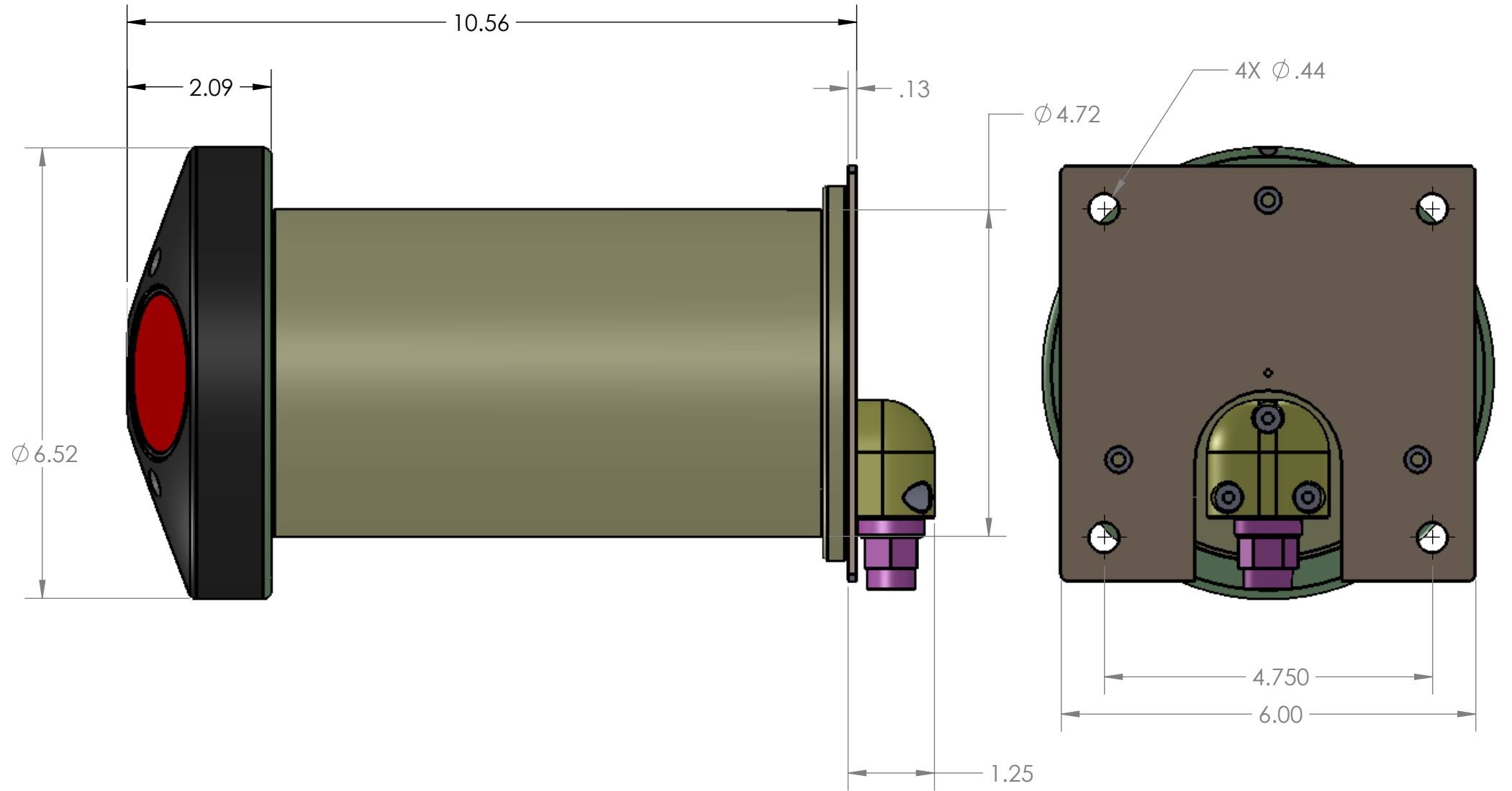
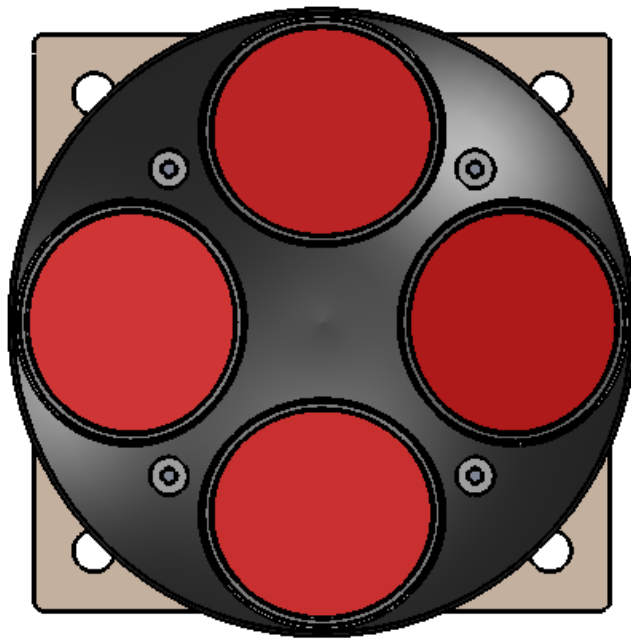

PROPRIETARY AND CONFIDENTIAL
 THE INFORMATION CONTAINED IN THIS DRAWING IS THE SOLE PROPERTY OF Rowe Technologies Inc.. ANY REPRODUCTION IN PART OR AS A WHOLE WITHOUT THE WRITTEN PERMISSION OF Rowe Technologies Inc. IS PROHIBITED.

UNLESS OTHERWISE SPECIFIED:		NAME	DATE	Rowe Technologies Inc. Poway CA, 92064	
DIMENSIONS ARE IN INCHES		DRAWN		TITLE: OUTLINE, 4500M DVL, OE	
TOLERANCES:		CHECKED			
FRACTIONAL ±		ENG APPR.			
ANGULAR: MACH ± BEND ±		MFG APPR.			
TWO PLACE DECIMAL ± .005		Q.A.		SIZE	DWG. NO.
THREE PLACE DECIMAL ± .002		COMMENTS:		B	10435
INTERPRET GEOMETRIC TOLERANCING PER:				REV	A
MATERIAL				SCALE: 1:4	SHEET 1 OF 1
NEXT ASSY	USED ON				
APPLICATION	DO NOT SCALE DRAWING				

8

7

6

5

4

3

2

1

8

7

6

5

4

3

2

1

REVISIONS

ECO NO	REV	DESCRIPTION	ENG DATE	APRV

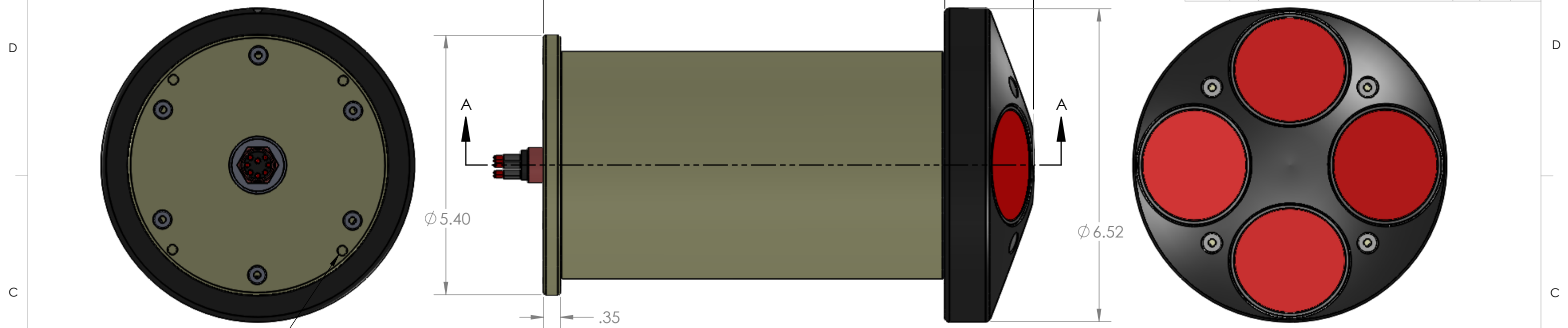

4X MOUNTING HOLES

.70 THICK TITANIUM PLATE

.70 THICK TITANIUM PLATE

BLACK ACETAL TRANSDUCER HOUSING CAP

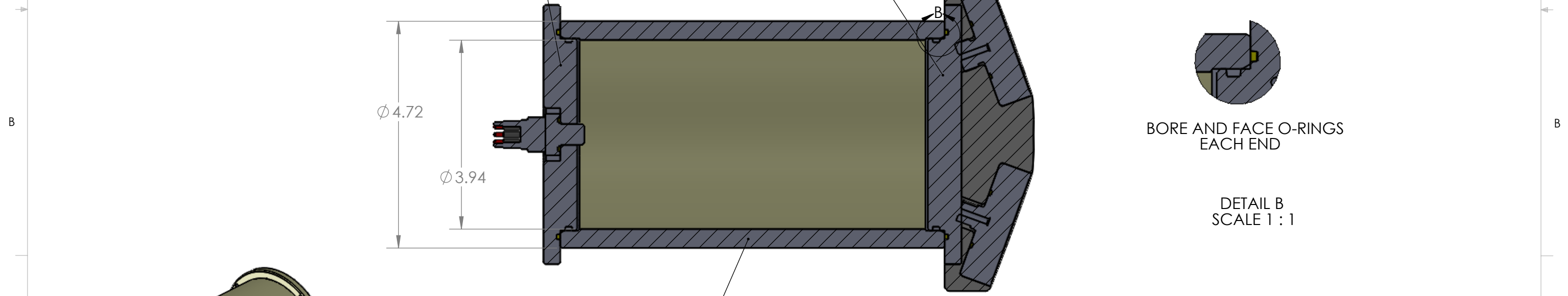

BORE AND FACE O-RINGS EACH END

DETAIL B
SCALE 1 : 1

TITANIUM TUBE

SECTION A-A
SCALE 1 : 2

PROPRIETARY AND CONFIDENTIAL
THE INFORMATION CONTAINED IN THIS DRAWING IS THE SOLE PROPERTY OF Rowe Technologies Inc.. ANY REPRODUCTION IN PART OR AS A WHOLE WITHOUT THE WRITTEN PERMISSION OF Rowe Technologies Inc. IS PROHIBITED.

UNLESS OTHERWISE SPECIFIED: DIMENSIONS ARE IN INCHES TOLERANCES: FRACTIONAL ± ANGULAR: MACH ± BEND ± TWO PLACE DECIMAL ± .005 THREE PLACE DECIMAL ± .002		DRAWN	NAME	DATE	Rowe Technologies Inc. Poway CA, 92064	
INTERPRET GEOMETRIC TOLERANCING PER:		CHECKED				TITLE: OUTLINE, 1200 600 DVL 6000M TITANIUM
MATERIAL		ENG APPR.				
FINISH		MFG APPR.				SIZE B DWG. NO. 10336 REV A
NEXT ASSY	USED ON	Q.A.	COMMENTS:		SCALE: 1:4 SHEET 1 OF 1	
APPLICATION		DO NOT SCALE DRAWING				

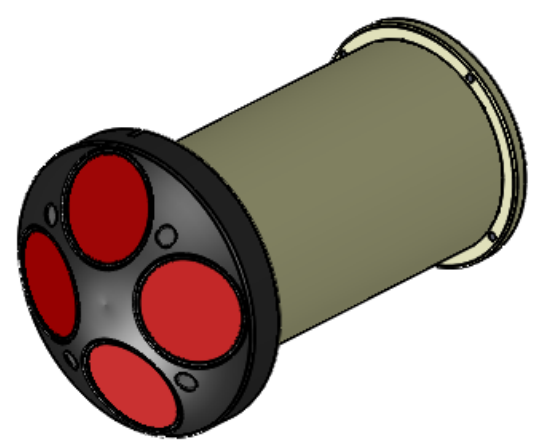

REVISIONS			
ECO NO	REV	DESCRIPTION	ENG DATE APRV

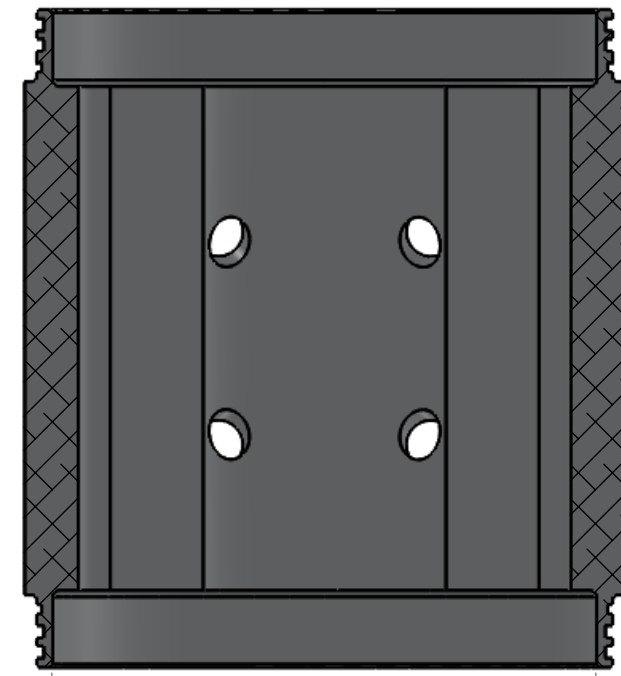

SECTION A-A
SCALE 1 : 3

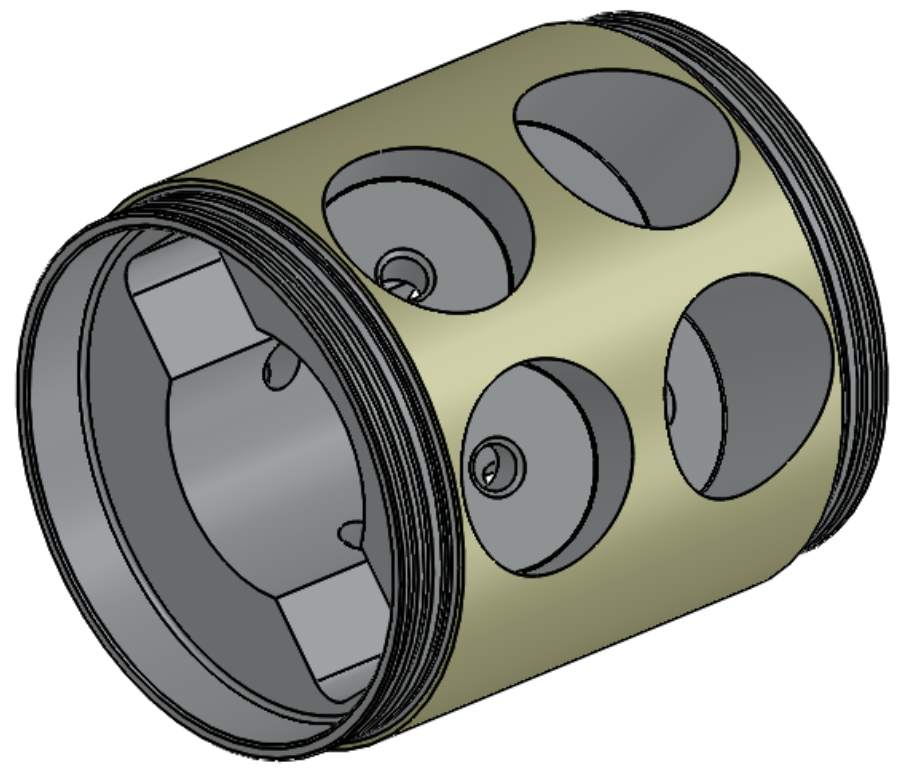
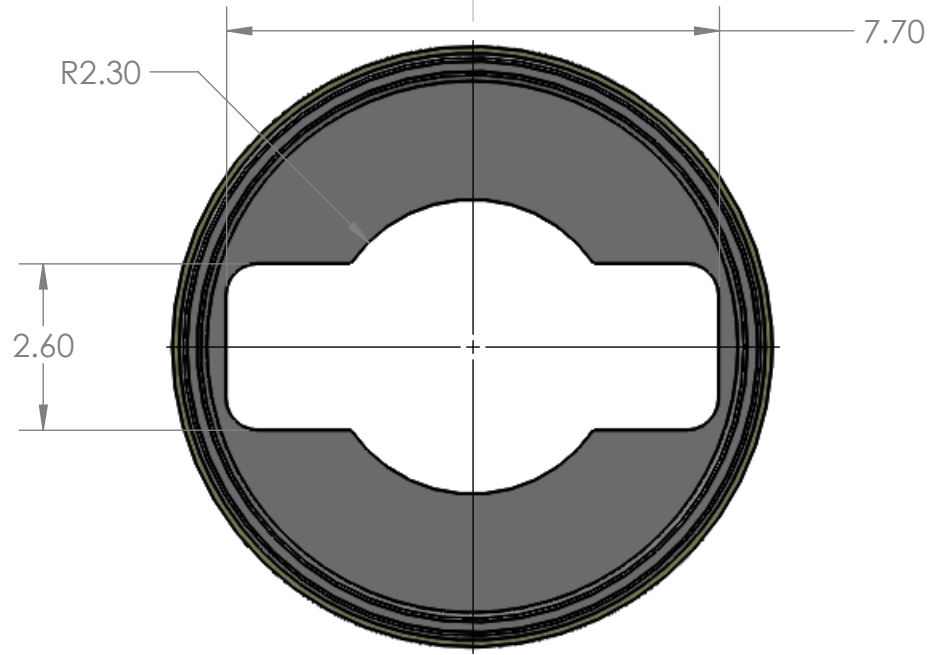
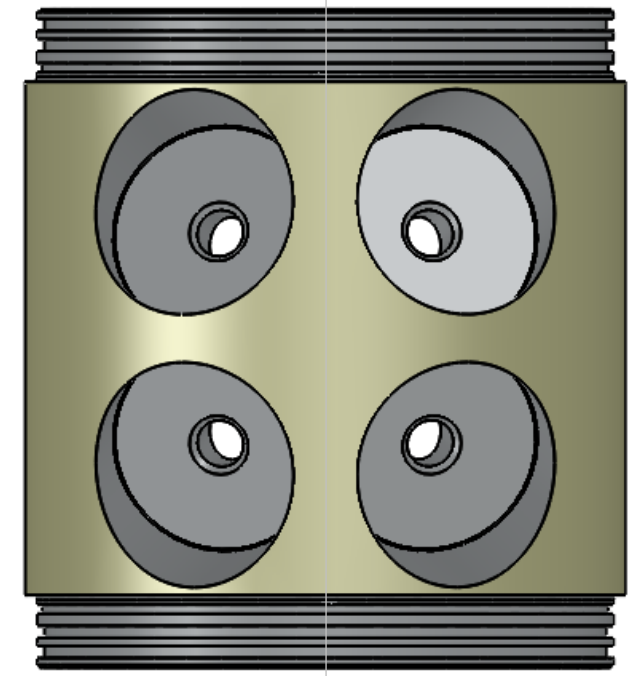
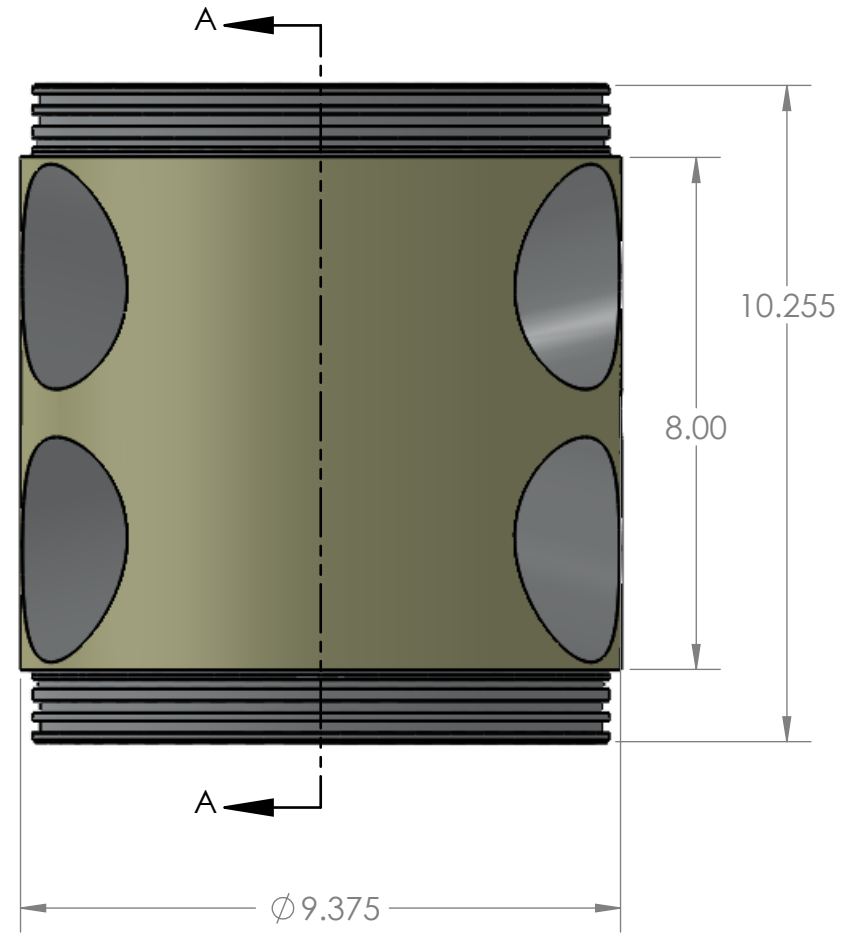

PROPRIETARY AND CONFIDENTIAL
THE INFORMATION CONTAINED IN THIS DRAWING IS THE SOLE PROPERTY OF Rowe Technologies Inc.. ANY REPRODUCTION IN PART OR AS A WHOLE WITHOUT THE WRITTEN PERMISSION OF Rowe Technologies Inc. IS PROHIBITED.

UNLESS OTHERWISE SPECIFIED:		NAME	DATE	Rowe Technologies Inc. Poway CA, 92064	
DIMENSIONS ARE IN INCHES		DRAWN		TITLE: DVL, BLUEFIN, 8 BEAM UP / DOWN , 300/600	
TOLERANCES:		CHECKED			
FRACTIONAL ±		ENG APPR.			
ANGULAR: MACH ± BEND ±		MFG APPR.			
TWO PLACE DECIMAL ± .005		Q.A.		SIZE	DWG. NO.
THREE PLACE DECIMAL ± .002		COMMENTS:		B	10390
INTERPRET GEOMETRIC TOLERANCING PER:				REV	A
MATERIAL				SCALE: 1:4	SHEET 1 OF 1
FINISH					
NEXT ASSY	USED ON				
APPLICATION		DO NOT SCALE DRAWING			