

REVISIONS				
ECO NO	REV	DESCRIPTION	ENG DATE	APRV

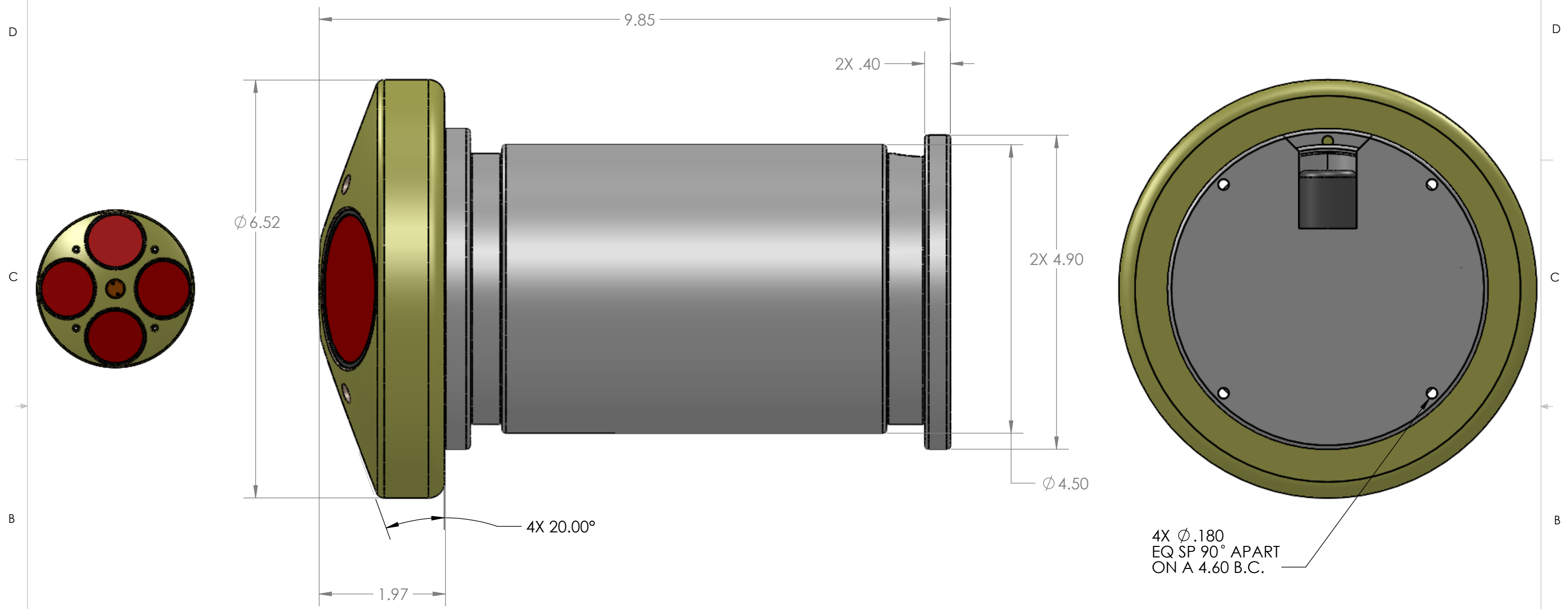

WEIGHT IN AIR: 7 LBS
 WEIGHT IN WATER: 1 LBS

PROPRIETARY AND CONFIDENTIAL
 THE INFORMATION CONTAINED IN THIS DRAWING IS THE SOLE PROPERTY OF Rowe Technologies Inc.. ANY REPRODUCTION IN PART OR AS A WHOLE WITHOUT THE WRITTEN PERMISSION OF Rowe Technologies Inc. IS PROHIBITED.

UNLESS OTHERWISE SPECIFIED:		NAME	DATE	Rowe Technologies Inc. Poway CA, 92064
DIMENSIONS ARE IN INCHES		DRAWN		
TOLERANCES:		CHECKED		TITLE: 6001200 KHZ ASSY,
FRACTIONAL \pm		ENG APPR.		
ANGULAR: MACH \pm BEND \pm		MFG APPR.		
TWO PLACE DECIMAL $\pm .005$		Q.A.		SIZE DWG. NO. REV B 10420 A
THREE PLACE DECIMAL $\pm .002$		COMMENTS:		
INTERPRET GEOMETRIC TOLERANCING PER:				SCALE: 1:4
MATERIAL ACETAL HGS				SHEET 1 OF 1
FINISH				
NEXT ASSY	USED ON			
APPLICATION				
DO NOT SCALE DRAWING				

PCSI-RB (River-Boat)

Body : made by Plastic

Stand : Aluminum Stainless Steel

Length : 48" or 121 cm

Width : 32" or 81 cm

Weight : 15 lbs. or 7 kg



Antenna (fixed on boat)

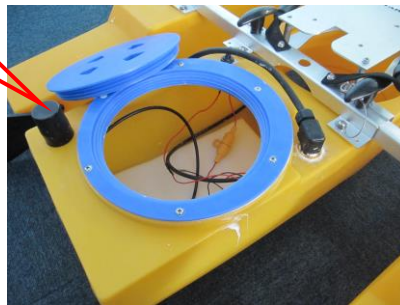

ADCP mounting area

Water Compartment



HCAS : ATA-style wood and aluminum case with metal hardware and wheels to fit disassembled boat.

Case Size : L*W*H 133*43*46cm



SCAS: Soft Case for Riverboat

