



US010698107B2

(12) **United States Patent**  
**Rowe et al.**

(10) **Patent No.:** **US 10,698,107 B2**  
(45) **Date of Patent:** **\*Jun. 30, 2020**

(54) **MULTI FREQUENCY 2D PHASED ARRAY TRANSDUCER**

(71) Applicant: **ROWE TECHNOLOGIES, INC.**,  
Poway, CA (US)

(72) Inventors: **Francis Dale Rowe**, Poway, CA (US);  
**John Romeo**, San Marcos, CA (US)

(73) Assignee: **Rowe Technologies, Inc.**, Poway, CA  
(US)

(\* ) Notice: Subject to any disclaimer, the term of this  
patent is extended or adjusted under 35  
U.S.C. 154(b) by 19 days.

This patent is subject to a terminal dis-  
claimer.

(21) Appl. No.: **16/105,487**

(22) Filed: **Aug. 20, 2018**

(65) **Prior Publication Data**

US 2019/0086538 A1 Mar. 21, 2019

**Related U.S. Application Data**

(63) Continuation of application No. 13/282,257, filed on  
Oct. 26, 2011, now Pat. No. 10,054,681.  
(Continued)

(51) **Int. Cl.**  
**G01S 15/89** (2006.01)  
**B06B 1/06** (2006.01)  
(Continued)

(52) **U.S. Cl.**  
CPC ..... **G01S 15/89** (2013.01); **B06B 1/0622**  
(2013.01); **B06B 1/0625** (2013.01);  
(Continued)

(58) **Field of Classification Search**  
USPC ..... 367/138  
See application file for complete search history.

(56) **References Cited**

U.S. PATENT DOCUMENTS

3,587,561 A 6/1971 Ziedonis et al.  
3,953,828 A 4/1976 Cook  
(Continued)

FOREIGN PATENT DOCUMENTS

CA 2092564 C 6/2001  
CN 1117139 A 2/1996  
(Continued)

OTHER PUBLICATIONS

Aydogdu E., et al., "Nonlinear Equivalent Circuit Model for Cir-  
cular CMUTs in Uncollapsed and Collapsed Mode." 2012 IEEE  
International Ultrasonics Symposium, IEEE, 2012.

(Continued)

*Primary Examiner* — James R Hulka

(74) *Attorney, Agent, or Firm* — Gazdzinski &  
Associates, PC

(57) **ABSTRACT**

Improved two-dimensional planar array transducer and  
beamformer apparatus and methods. In one embodiment, the  
two-dimensional planar array transducer is capable of simul-  
taneously or sequentially forming multiple acoustic beams  
in two axes and at two or more widely separated acoustic  
frequencies from a single flat planar array transducer. The  
transducer planar array consists of two or more electrically  
and acoustically independent two dimensional planar trans-  
ducer array structures operating at different frequencies that  
are physically integrated onto a single multi frequency  
configuration. In an exemplary embodiment, a second higher  
frequency transducer array is positioned within the aperture  
area of a lower frequency planar array transducer. Methods  
of using the aforementioned two-dimensional planar array  
transducer and beamformer are also disclosed.

**20 Claims, 4 Drawing Sheets**

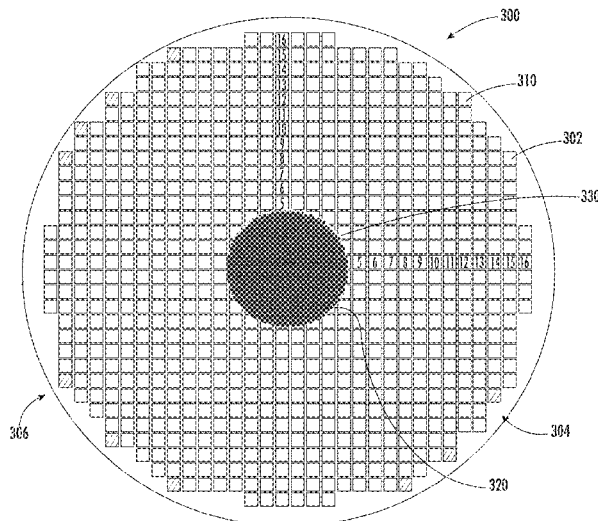

**Related U.S. Application Data**

- (60) Provisional application No. 61/456,086, filed on Nov. 1, 2010.
- (51) **Int. Cl.**  
*G01S 15/58* (2006.01)  
*G01S 15/60* (2006.01)  
*G01S 7/52* (2006.01)  
*H04R 1/40* (2006.01)
- (52) **U.S. Cl.**  
 CPC ..... *G01S 7/52003* (2013.01); *G01S 15/58* (2013.01); *G01S 15/60* (2013.01); *H04R 1/40* (2013.01); *H04R 2201/401* (2013.01); *H04R 2201/403* (2013.01)

2010/0142324	A1	6/2010	Vogt	
2010/0157739	A1	6/2010	Slocum et al.	
2010/0195443	A1	8/2010	Lawhite et al.	
2011/0075518	A1	3/2011	Huhta et al.	
2011/0189350	A1	8/2011	Van Belleghem et al.	
2011/0189440	A1	8/2011	Appleby et al.	
2012/0007472	A1	1/2012	Tai et al.	
2012/0106299	A1	5/2012	Rowe et al.	
2012/0163126	A1	6/2012	Campbell et al.	
2014/0113828	A1	4/2014	Gilbert et al.	
2014/0230567	A1	8/2014	Rowe et al.	
2015/0049590	A1*	2/2015	Rowe .....	B06B 1/0629 367/138
2018/0172492	A1*	6/2018	Rowe .....	G01S 15/582
2019/0257930	A1*	8/2019	Sarangapani .....	G01S 7/521
2019/0310117	A1*	10/2019	Rowe .....	G01F 1/667

**FOREIGN PATENT DOCUMENTS**

- (56) **References Cited**  
 U.S. PATENT DOCUMENTS

CN	1901837	A	1/2007
WO	WO-2005065408	A2	7/2005
WO	WO-2010111157	A1	9/2010

**OTHER PUBLICATIONS**

4,100,527	A	7/1978	Tocquet	
4,916,675	A	4/1990	Hoering	
5,077,700	A	12/1991	Shaw et al.	
5,122,990	A	6/1992	Deines et al.	
5,208,785	A	5/1993	Brumley et al.	
5,343,443	A	8/1994	Merewether	
5,615,173	A	3/1997	Brumley et al.	
5,617,865	A	4/1997	Palczewska et al.	
5,689,445	A	11/1997	Vogt et al.	
5,808,967	A	9/1998	Yu et al.	
5,923,617	A	7/1999	Thompson et al.	
6,052,334	A	4/2000	Brumley et al.	
6,097,671	A	8/2000	Merewether	
6,183,419	B1	2/2001	Wildes	
6,282,151	B1	8/2001	Brumley et al.	
6,647,804	B1	11/2003	Deines	
6,678,210	B2	1/2004	Rowe	
6,700,834	B2	3/2004	Brumley et al.	
6,714,482	B2	3/2004	Rowe	
6,821,251	B2	11/2004	Alexandru	
7,317,660	B2	1/2008	Brumley et al.	
7,527,592	B2	5/2009	Haugen et al.	
7,542,374	B2	6/2009	Brumley et al.	
7,847,925	B2	12/2010	Vogt	
RE43,090	E	1/2012	Rowe	
8,223,588	B2	7/2012	Lohrmann et al.	
8,254,208	B2	8/2012	Vogt	
8,411,530	B2	4/2013	Slocum et al.	
8,470,605	B2	6/2013	Putnam et al.	
8,512,250	B2	8/2013	Quistgaard	
9,823,104	B2*	11/2017	Rowe .....	G01F 1/667
10,260,920	B2*	4/2019	Rowe .....	G01F 1/002
2002/0126577	A1	9/2002	Borchardt	
2003/0076742	A1	4/2003	Rowe	
2003/0127609	A1	7/2003	El-Hage et al.	
2003/0214880	A1*	11/2003	Rowe .....	G10K 11/343 367/103
2003/0235112	A1	12/2003	Zimmerman et al.	
2006/0042389	A1	3/2006	Sato et al.	
2006/0063271	A1	3/2006	Putnam et al.	
2006/0155492	A1	7/2006	Strong et al.	
2008/0079332	A1	4/2008	Rorick	
2008/0080313	A1	4/2008	Brumley et al.	
2008/0080314	A1	4/2008	Brumley et al.	
2008/0316866	A1	12/2008	Goodemote et al.	
2009/0052282	A1	2/2009	Strong et al.	
2009/0182237	A1	7/2009	Angelsen et al.	

Bird, "Coherent Clutter Removal and Doppler Estimation", Simon Frazer University, 2012.

Brumley, et al., "Performance of a Broad-Band Acoustic Doppler Current Profiler", IEEE Journal of Oceanic Engineering, vol. 16, No. 4, Oct. 1991, pp. 402-407.

Cabrera, et al., American Society of Civil Engineers, "Side Looking Doppler Velocity Sensors", Jul. 30-Aug. 2, 2000.

Frazier, "A two-dimensional amplitude-steered array for real-time volumetric imaging," Doctoral Thesis, University of Illinois at Urbana-Champaign, pp. 170 (Apr. 2000).

Frazier, et al., Analysis of Resolution for an Amplitude Steered Array, 1999 IEEE Ultrasonics Symposium pp. 1231.

Goss, et al., "An introduction to WSR-88C clutter suppression", NEXTRAD weather service.

Huddleston, et al., "Tools for Technicians; Lessons Learned in Index-Velocity Site Selection and ADVDM Setup", May 2007.

LeCoz, et al., "Evaluation of river discharges monitored by a fixed sidelooking Doppler Profiler", Jun. 2008.

Lee, et al., "Radar clutter suppression using adaptive algorithms", Aerospace conference 2004, IEEE proceedings, vol. 3.

Moore, et al., "Measuring river flow using side-looking Acoustic Doppler Current Profilers: a comparison to vertically-oriented ADCP results" (2009).

Morlock, S.E., 1994, Evaluation of acoustic Doppler current profiler measurements of river discharge: "U.S. Geological Survey Water-Resources Investigation Report 95-4218, 37".

RD Instruments, Technical Note "Subject: RDI's Phased Array Technology", Feb. 28, 2003.

Ruhl, C.A., and Simpson, M.R., 2005, "Computation of discharge using the index-velocity method in tidally affected areas", U.S. Geological Survey Scientific Investigations Report 2005-5004, 31

H.Hidayat, B. Vermeulen, M.G. Sassi, P. Torts, A. Hoitink, "Discharge estimating in a backwater affected meandering river", Mar 2011.

USGS "Index-velocity and Other Fixed-deployment Instruments" obtained from <http://hydroacoustics.usgs.gov/indexvelocity/instruments.shtml> on Mar. 1, 2013.

Vougioukas, et al., "Application note: River discharge monitoring using a vertically moving side-looking acoustic Doppler profiler".

\* cited by examiner

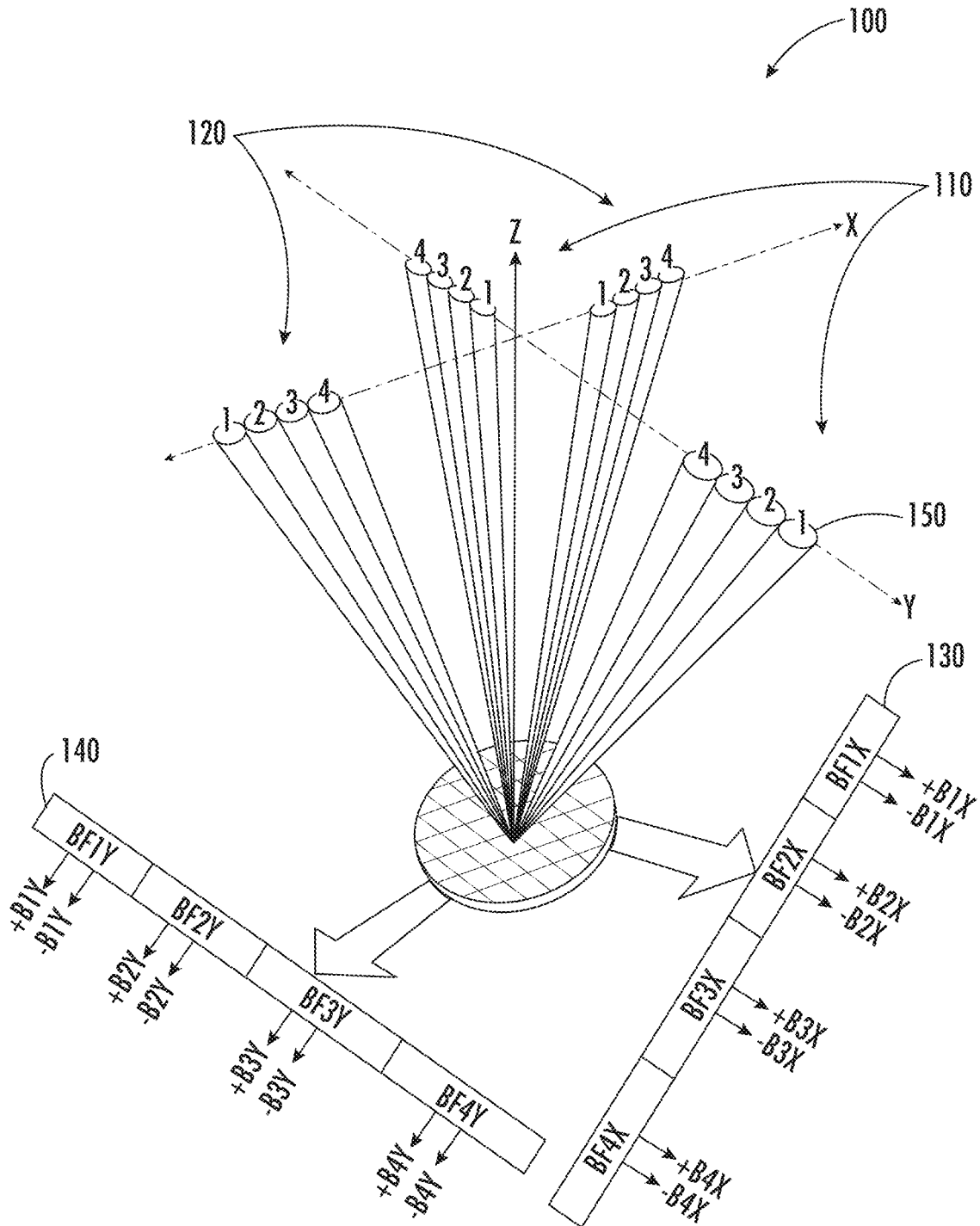

FIG. 1  
PRIOR ART

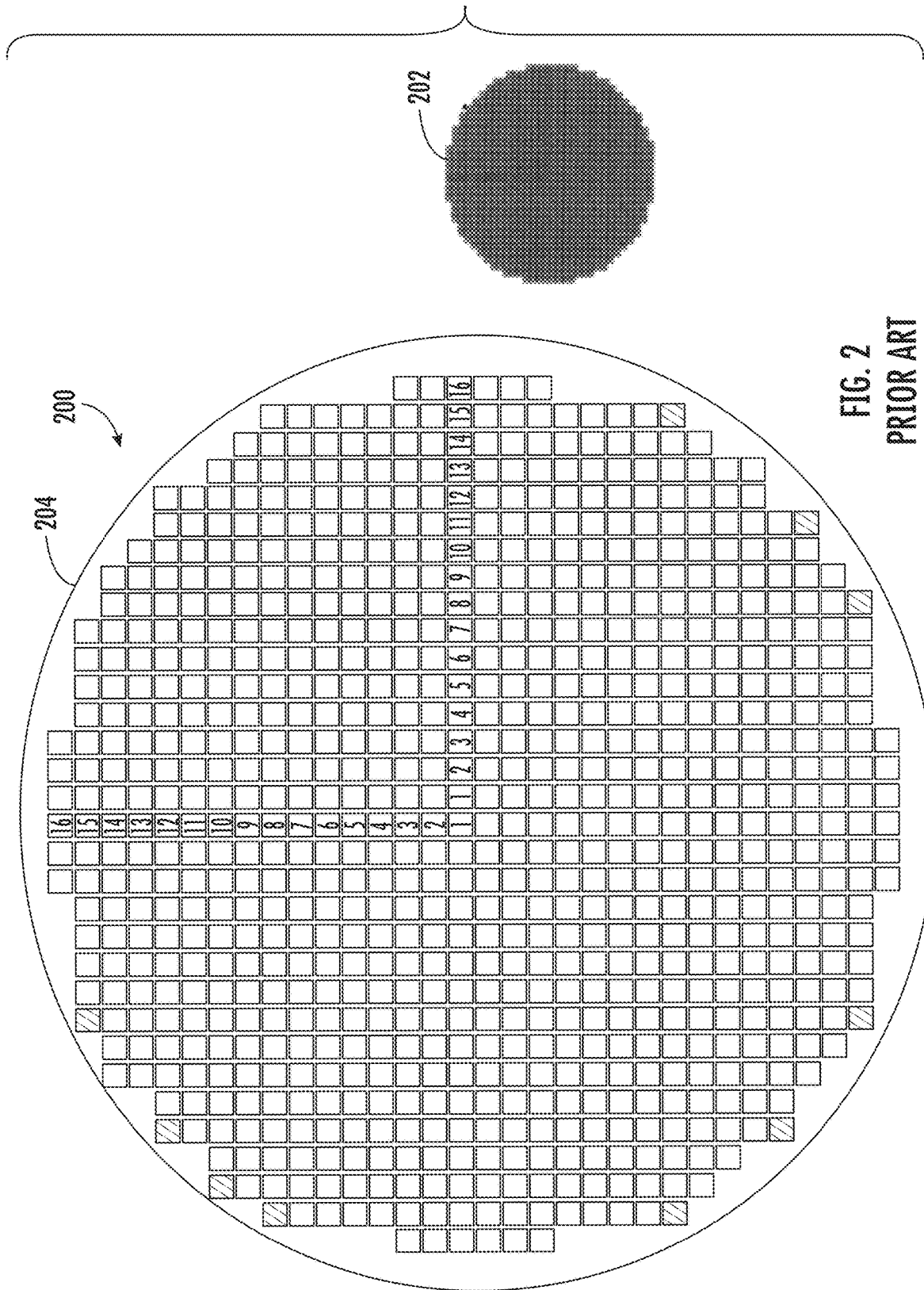

FIG. 2  
PRIOR ART

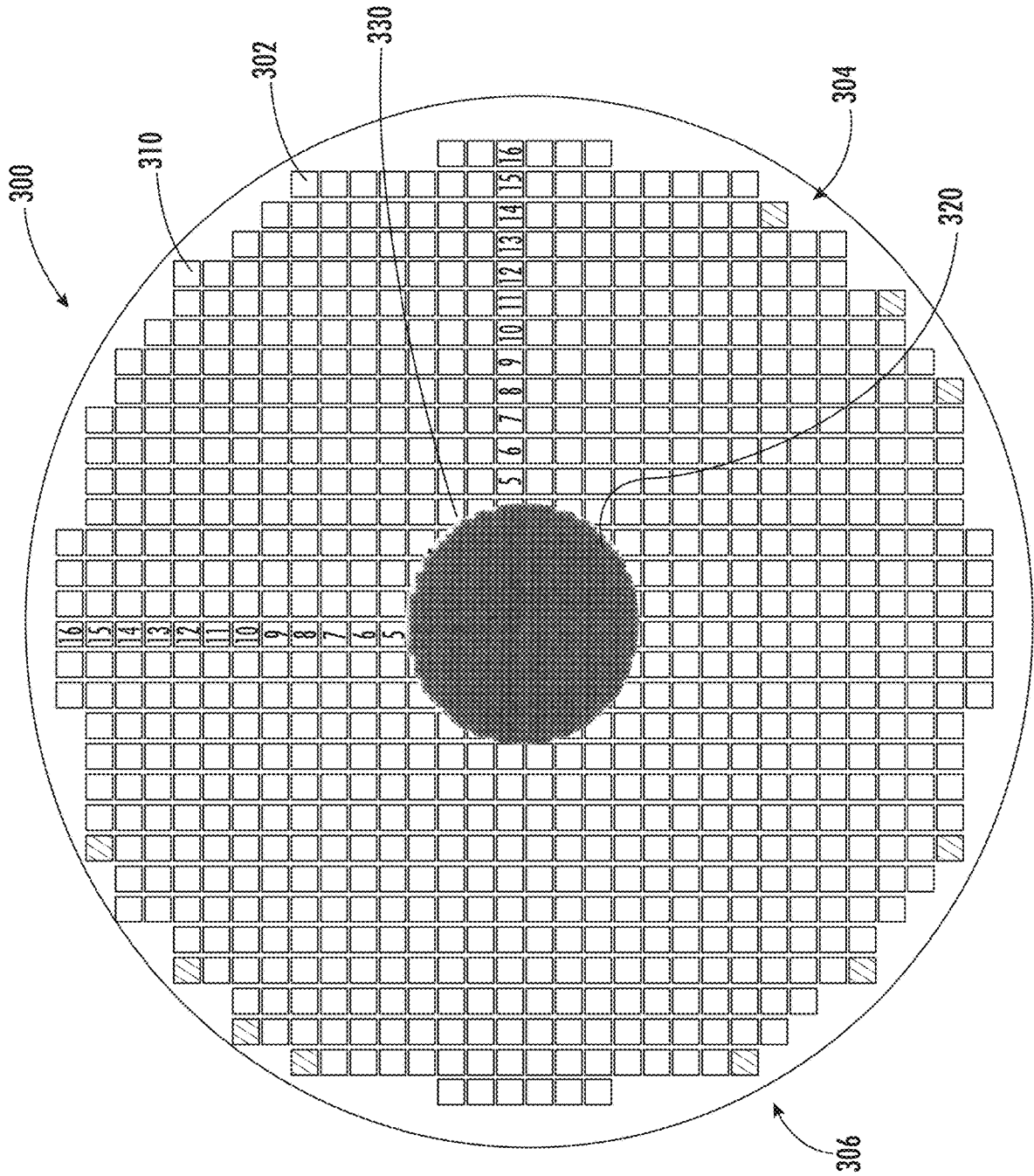

FIG. 3

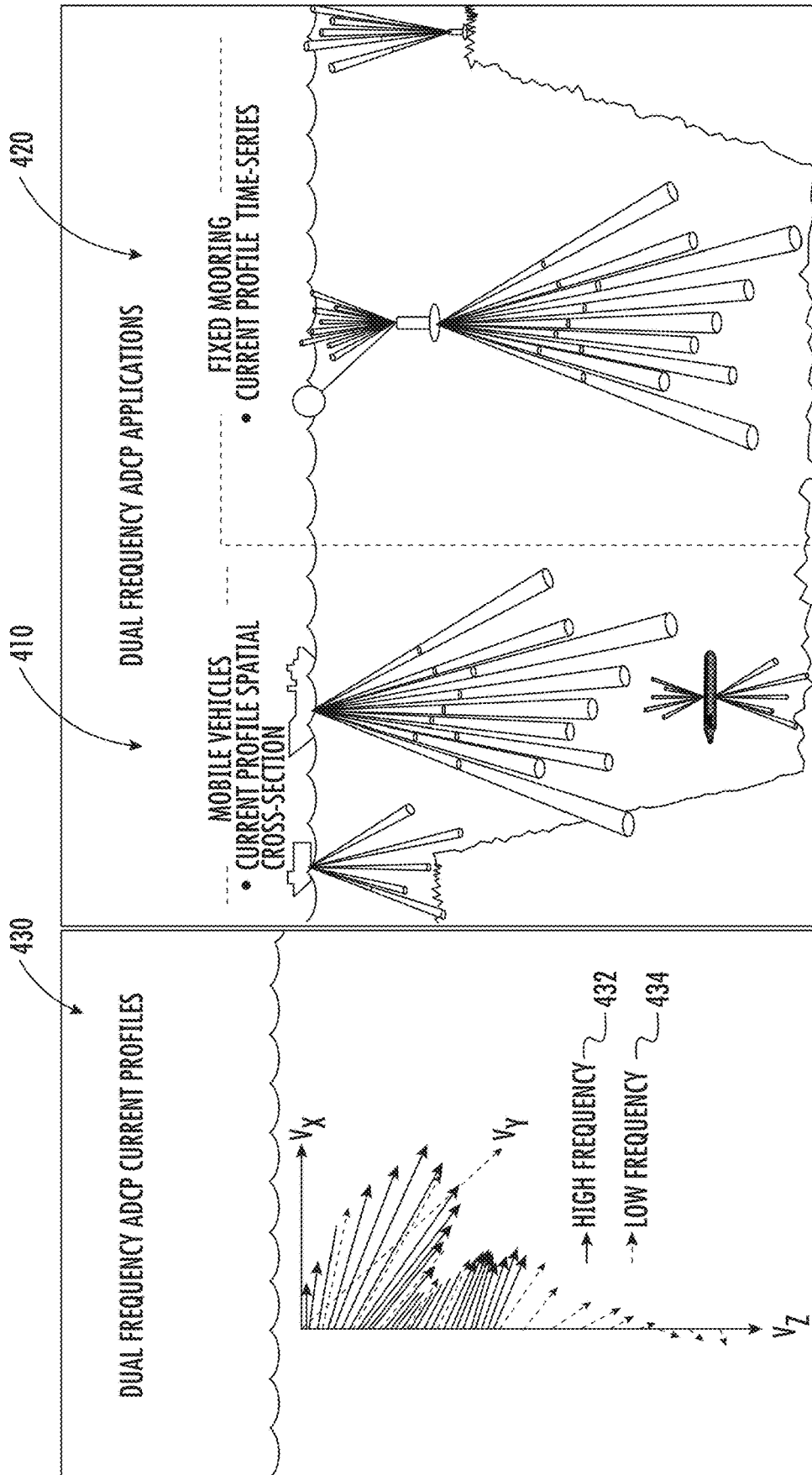

FIG. 4

## MULTI FREQUENCY 2D PHASED ARRAY TRANSDUCER

### PRIORITY

This application is a continuation of, and claims the benefit of priority to, co-owned U.S. patent application Ser. No. 13/282,257 filed Oct. 26, 2011 of the same title, which claims the benefit of priority to U.S. Provisional Patent Application Ser. No. 61/456,086 filed Nov. 1, 2010 of the same title, each of which is incorporated herein by reference in its entirety.

### COPYRIGHT

A portion of the disclosure of this patent document contains material that is subject to copyright protection. The copyright owner has no objection to the facsimile reproduction by anyone of the patent document or the patent disclosure, as it appears in the Patent and Trademark Office patent files or records, but otherwise reserves all copyright rights whatsoever.

#### 1. Field of the Invention

The present invention relates generally to a planar array sonar transducer and in one exemplary aspect to a multi-frequency planar array sonar transducer for generating acoustic Doppler current profiles.

#### 2. Description of Related Technology

Sonar transducers are currently used in different types of acoustic backscatter systems that measure velocity and/or distance in two or three dimensions. One such sonar transducer is disclosed in U.S. Pat. No. 5,808,967 which discloses an acoustic planar array transducer that forms multiple beams at a single or relatively narrow range of frequencies along two axes of a single two-dimensional ("2D") phased array transducer. FIG. 1 illustrates such an acoustic array transducer **100**. One pair of beams **110** is formed by connecting a beamformer to a first set of electrodes on one side of the transducer and the other pair **120** is formed by connecting a second beamformer to a second set of electrodes on the other side of the transducer. The electrodes on each side of the transducer are parallel thin lines of copper that are closely spaced and run across the entire dimension of the transducer in one direction. The electrodes on one side of the transducer run in the orthogonal direction relative to those on the other side of the transducer.

In order to simultaneously and independently form each pair of beams on both transmit and receive channels, two separate and independent transmit beamformers **130** and two separate and independent receive beamformers **140** are used. A transmit/receive switch (not shown) is also used to connect one transmit beamformer and one receive beamformer to the electrical contacts on one side of the transducer. A second and independent transmit and receive beamformer pair is connected through a second transmit/receive switch to the contacts on the second side of the transducer. The two transmit and receive beamformers are used to simultaneously generate two or more pairs of independent beams in each X and Y axis. One pair is inclined from broadside and orthogonal to the electrodes on one side of the transducer and the other pair is inclined from broadside and orthogonal to the electrodes on the other side of the transducer. Although these beams are in fixed locations, the fact that the

beamformers are both simultaneous and independent allows for the possibility of concurrent and independent steering of one set of beams relative to the other. Furthermore, if the transducer electrodes are brought into the beamformers individually each beamformer could potentially generate a completely independent set of arbitrary simultaneous beams along each of the two orthogonal X and Y axes.

Alternate 2D planar array transducers are also used where the beam sets in each axis are not simultaneous, or independently formed. While these classes of 2D planar array sonars generally only require a single beamformer for transmit and/or receive thereby resulting in significantly less beamformer complexity, these types of alternate 2D planar array transducers have disadvantages such as having a fewer number of beams simultaneously formed and incomplete independence of the multiple 2D beams. In addition, the range of frequencies which these 2D planar array transducers and beamformers can generate acoustic beams is limited by the bandwidth achievable by the bandwidth of the transducer array itself. This is approximately fifty percent (50%), or a factor of 0.5, of a nominal operating frequency. Thus, the transducer is limited to about twenty-five percent (25%) above or twenty-five percent (25%) below a nominal operating frequency.

In many applications such as Acoustic Doppler Current Profiler (ADCP) applications, at least three (3) and usually four (4) inclined narrow beams **150** along two axes are required to measure three (3) dimensional currents in the water column. In ADCP applications from a surface vessel, it is desirable to measure current profiles throughout a given water column, however, the region of the water column near the surface is a more spatially and velocity dynamic (characterized by small scale variations in water velocity and scattering particles in the water) than the deeper water column. Accordingly, it is desirable to measure the shallower, near transducer region with a higher spatial, temporal and velocity resolution than the longer range region. For this class of 2D sonar applications, with the near dynamic and deeper less dynamic water motion, this can be best achieved by operating with two sonars separated in frequency by an approximate factor of four (4). Operation at the lower frequency provides greater sonar range (for use at deeper water column depths), but has less spatial, velocity, and temporal resolution. Conversely, operation at a higher frequency has less range, but provides better range, velocity and temporal resolution over the range (i.e. depth) which it can reach.

Currently, when using 2D planar array transducers for applications such as current profiling, this dual sonar frequency operation is achieved by using two physically separate and independent 2D planar array transducers. A face view of these two 2D planar array transducers **200** operating at frequencies separated by a factor of four (4) is illustrated in FIG. 2. For equivalent beamwidths from both arrays, the high frequency transducer **202** has a diameter that is a factor of four (4) smaller than the low frequency transducer **204** as the acoustic wavelength in water is a factor of four (4) smaller. Each circular transducer is eight (8) half ( $\frac{1}{2}$ ) wavelength's wide on each side of its centerline. This two-transducer sonar provides the desired performance of high resolution over short range and long range lower resolution; however such a configuration is undesirable in that each transducer must be separately installed onto the vessel hull at locations where both transducer faces are exposed to the water. Accordingly, when installed in a vessel

hull, this two transducer approach requires two hull penetrations, which can: (1) be expensive to install; and (2) be difficult to locate in the hull.

Accordingly, there is still a salient need for transducer arrays that can provide varying levels of spatial, velocity, and temporal resolution while being embodied within a single discrete form factor. Ideally such a solution will achieve such a desired form factor while providing comparable performance with multiple discrete transducer designs.

#### SUMMARY OF THE INVENTION

The present invention addresses the foregoing needs by providing improved transducer apparatus and methods of use.

In a first aspect of the invention, a transducer array is disclosed. In one embodiment, the transducer array includes two distinctly sized transducer arrays that correlate with two different operating frequencies, respectively, that are embodied within a single unitary planar array structure.

In one variant, the first transducer array includes a central portion that does not contain any of transducer elements for that first transducer array.

In another variant, the second transducer array is positioned within this central portion.

In yet another variant, the first transducer array occupies a first symmetrical area portion of the single flat planar surface while the second transducer array occupies a second symmetrical area portion of the single flat planar surface.

In yet another variant, the second symmetrical area portion is disposed entirely within the first symmetrical area portion.

In yet another variant, the second symmetrical area portion is substantially concentric with the first symmetrical area portion.

In yet another variant, the second symmetrical area portion occupies less than ten percent of the first symmetrical area portion.

In yet another variant, the first plurality of transducer elements is made up of an array having a row of a value M transducer elements and a column of a value N transducer elements.

In yet another variant, the second array of transducer elements is made up of an array having a row of a value X transducer elements and a column of having a value Y of transducer elements.

In one variant, the value M is equal to the value X and the value N is equal to the value Y.

In yet another variant, the value M is equal to the value N.

In a second aspect of the invention, a multi-frequency transducer array for use in an acoustic Doppler current profiler (ADCP) application is disclosed. In one embodiment, the multi-frequency transducer array includes a single transducer array structure having a first transducer array optimized for operation at a first depth and a second transducer array optimized for operation at a second depth different than the first depth.

In one variant, the first depth is expected to have a more spatially and velocity dynamic current than the second depth.

In an alternative variant, the first and second transducer array optimization comprises the configuration of an operating frequency for the first and second transducer arrays, respectively.

In yet another variant, the first transducer array comprises a fully filled array structure while the second transducer array comprises a partially filled array structure.

In yet another variant, the first transducer array is configured to operate at a first nominal operating frequency while the second transducer array is configured to operate at a second nominal operating frequency different than the first nominal operating frequency.

In yet another variant, the difference between the first and second nominal operating frequencies is greater than or equal to a factor of four.

In a third aspect of the invention, a transducer array is disclosed. In one embodiment, the transducer array includes a singular planar structure comprising at least two electrically and acoustically independent two dimensional planar transducers.

In one variant, the singular planar structure is configured to simultaneously or sequentially form multiple acoustic beams at two or more separated acoustic frequencies.

In yet another variant, the singular planar structure is further configured to simultaneously or sequentially form multiple acoustic beams along two axes.

In a fourth aspect of the invention, a marine vessel that includes any of the aforementioned transducer arrays is disclosed. In one embodiment, the marine vessel includes a surface ship. In another embodiment, the marine vessel includes a submersible vessel. In yet another embodiment, the marine vessel includes a stationary buoy.

In a fifth aspect of the invention, methods of using any of the aforementioned transducer arrays are disclosed.

These and other aspects of the invention shall become apparent when considered in light of the disclosure provided herein.

#### BRIEF DESCRIPTION OF THE DRAWINGS

The features, objectives, and advantages of the invention will become more apparent from the detailed description set forth below when taken in conjunction with the drawings, wherein:

FIG. 1 is a functional block diagram of a prior art two-dimensional transducer array.

FIG. 2 illustrates a face view of two (2) prior art two-dimensional thirty-two by thirty-two half wavelength spaced planar array transducer elements with the larger transducer operating at a factor of four lower acoustic frequency.

FIG. 3 illustrates a face view of a single dual frequency two-dimensional thirty-two by thirty-two element planar array transducer in accordance with the principles of the present invention.

FIG. 4 illustrates various applications and a current profile for dual frequency Acoustic Doppler Current Profiler (ADCP) applications in accordance with the principles of the present invention.

All Figures disclosed herein are © Copyright 2010-2011 Rowe Technologies, Inc. All rights reserved.

#### DETAILED DESCRIPTION OF THE PREFERRED EMBODIMENT

Reference is now made to the drawings wherein like numerals refer to like parts throughout.

Overview  
The present invention provides, inter alia, an improved two-dimensional (2D) planar array transducer and beam-former which is capable of simultaneously or sequentially forming multiple acoustic beams in two axes and at two or



more widely separated acoustic frequencies from a single flat planar array transducer. The transducer planar array consists of two or more electrically and acoustically independent two dimensional planar transducers operating at different frequencies and physically integrated into a single multi frequency configuration within the aperture area of a single planar array transducer.

#### Detailed Description of Exemplary Embodiments

Detailed descriptions of the various embodiments and variants of the apparatus and methods of the invention are now provided. While primarily discussed in the context of Acoustic Doppler Current Profiler (ADCP) applications, the various apparatus and methodologies discussed herein are not so limited. In fact, many of the apparatus and methodologies described herein are useful in any planar array transducer where significant operating frequency is advantageous, and where overall multiple transducer apertures are also important. For example, many imaging and bathymetry sonars employ 1D or 2D planar arrays, and use two (2) physically separate sets of these arrays to achieve high resolution at shorter ranges, and lower resolution at longer ranges. In addition, many modern ocean going vessels employ such physically separate multiple sonars for this purpose. The same techniques described herein with respect to 2D ADCP sonar applications may equally be applied to these applications.

Furthermore, while primarily discussed in the context of a dual frequency two dimensional (2D) planar transducer having two distinct transducer arrays, it is appreciated that additional transducer arrays (i.e. three (3) or more) could be embodied within a 2D planar transducer in accordance with embodiments of the present invention as described subsequently herein. In addition, certain features discussed with respect to specific embodiments can, in many instances, be readily adapted for use in one or more other contemplated embodiments that are described herein. It can be readily recognized by one of ordinary skill, given the present disclosure that many of the features described herein possess broader usefulness outside of the specific examples and implementations with which they are described.

#### Multiple Frequency 2D Planar Array Transducers

Referring now to FIG. 3, a face view of a single planar array transducer **300** which is capable of simultaneously or sequentially forming multiple acoustic beams in two axes and at two or more widely separated acoustic frequencies from a single flat 2D planar array transducer is illustrated. The transducer planar array consists of two electrically and acoustically independent 2D planar transducers **310**, **320** which are physically integrated into a single multi-frequency configuration. Individual array elements **302** within both the acoustically independent 2D planar transducers are electrically interconnected along front-side columns **304** and back-side rows **306**. In the illustrated embodiment, the array face is circular; however other symmetrical geometries (e.g. ellipses or polygons) are also suitable for many acoustic beam sonar applications. Each of the array elements are composed of symmetrical faces (squares as illustrated in FIG. 3) with a face width equal to approximately half the acoustic wavelength in water of the desired nominal frequency.

The larger array **310**, hereinafter referred to as the first array, consists of a plurality of transducer elements **302** separated by half a wavelength increments and arranged in a planar array of N (e.g., thirty-two (32)) substantially parallel rows and M (e.g., thirty-two (32)) substantially parallel columns. Each row of transducer elements is electrically connected along a first face of the array while each

column of transducer elements is electrically connected along a second face. Each of the transducer elements is further sized so as to be essentially identical. Beamformers are also employed and are connected to the lines on each face to form a first and second plane, respectively, of acoustic beams projected outside of the array plane.

The second smaller array **320** has, in the illustrated embodiment, the same configuration as the first larger array **310**, albeit sized smaller. The smaller size of the second array is specifically configured so as to operate at a relatively higher frequency of operation than the larger sized array, i.e. the transducer element width is configured so as to be approximately a fourth the acoustic wavelength in water for the desired higher frequency operation. While using even multiples of a desired acoustic frequency is not necessary, using an even factor (e.g. a factor of four) is sometimes convenient so that the same number of elements (e.g. 32x32) can be used on both the first and second arrays thereby providing the same acoustic beamwidth for each array. Furthermore, the transducer elements generally should be evenly spaced at fractional wavelengths so as to avoid grating lobes which can degrade the performance of the transducer array. The size of the second smaller array is determined based on the desired frequency disparity between the first and second arrays. For example, in a dual frequency application where it is desired that the two (2) frequencies be separated by a factor of four (4), and for equal values of N and M, the higher frequency array will have a respective cumulative diameter four (4) times less than the larger array. Accordingly, the smaller transducer array will occupy an area that is sixteen (16) times less than the first larger array due to the square relationship between the transducer array diameter and its associated area.

In one embodiment, and as illustrated in FIG. 3, a small section **330** in the center of the first array does not contain transducer elements of the first array **310** thereby enabling the 2D array transducer array to physically integrate the second smaller transducer array in this unoccupied center portion. This central area **330** configured for the second transducer array **320** is, in the illustrated embodiment, a factor of sixteen (16) less than the area required for the first array **310**. In other words, the area necessary to integrate the second array is in the illustrated embodiment eight (8) transducer elements wide and eight (8) transducer elements long when measured using the transducer elements of the first array. Accordingly, even though elements from the first array have to be removed in order to accommodate the second array, the first larger array still effectively has ninety-three percent (93%) of the elements that it would otherwise possess as compared with a fully filled first array. This allows the larger transducer array in FIG. 3 to achieve a beamwidth of ninety-three percent (93%) of that of a fully filled array. For many applications, this small decrease in beamwidth has a negligible effect on the overall system performance of the transducer array.

As discussed previously, the second 2D transducer array **320** is positioned within this center section in the illustrated embodiment of FIG. 3. Similar to the first 2D transducer array, the second 2D transducer array consists of an array of transducer elements that are, in the illustrated embodiment, spaced at one half wavelength increments measured center to center. Although other frequencies could be readily implemented, the wavelength of the illustrated second array is a factor of four (4) less than the first frequency array. Accordingly, for a given array size (e.g., N=32 and M=32) for both the low and high frequency arrays, the cumulative diameter of the second (higher frequency) array will be a factor of

four (4) less than the diameter of the low frequency array. As discussed previously, the second array only occupies a small fraction of the low frequency array surface area thereby permitting the low frequency array acoustic performance to be approximately equivalent to a fully filled two dimensional array. For a multi-frequency transducer array where the frequency difference is a factor of four (4), the center area required for the second high frequency array is less than seven percent (7%) of the total low frequency array size. As shown in FIG. 3, the second high frequency array is fully filled with array elements. However, it is appreciated that similar to the first low frequency array; the second array may also have a non-filled section (e.g. in the center) which is reserved for an additional (i.e. third) transducer array. For instance, and by way of a non-limiting example, a third array of transducer elements that are a factor of four (4) smaller than the second array could be integrated into the center portion of the second array. Additional layers or levels of transducer arrays (e.g. four (4) or more) could also be integrated into the single 2D transducer array form factor. By integrating multiple transducer arrays in this manner, a small higher frequency array may be physically embedded into the aperture of the lower frequency transducer without significantly degrading the performance of either sonar as compared with instances in which they are physical separated.

The dual frequency 2D planar array 300 is electrically coupled to beamforming circuitry to form the multiple beams from the different combinations of transducer elements (not shown) that is electrically connected to the transducer elements in each of the rows (N) and columns (M) of both the first lower frequency array and second higher frequency array. These beamforming circuits provide time and/or phase delays to the signals associated with each column and row, respectively. By providing time and/or phase delays to the signals associated with each column and row, a first and second plane of acoustic beams are formed that are projected outside of the array plane and are furthermore substantially normal to the first and second transducer array. Thus, the total physically integrated dual frequency array 300 provides multiple acoustic beams formed in two axes at two differing frequencies. The use of beamforming circuits and other circuitry useful in the application of the 2D transducer array described herein is described in, for example, U.S. Pat. No. 5,808,967 issued on Sep. 15, 1998 and entitled "Two-dimensional array transducer and beamformer", the contents of which are incorporated herein by reference in their entirety.

Referring now to FIG. 4, various dual frequency ADCP applications are shown. Specifically, FIG. 4 illustrates the operation of the dual frequency planar array transducer in a current profiling application where the dual frequency planar array transducer can operate from either a mobile surface vessel 410 or alternatively from a fixed (e.g. moored) location 420. The mobile surface vessels with the dual frequency planar array transducer can generate current profiles 430 as a function of depth. Current profiles with high temporal, spatial and velocity resolution utilize the embedded high frequency 2D transducer array to measure near the surface (where there are more spatially and velocity dynamic currents), while current profiles deeper in the water column (where there are less spatially and velocity dynamic currents) are measured using the low frequency 2D transducer array. Accordingly, this single multi-frequency ADCP achieves essentially identical performance of multiple discrete single frequency ADCPs, while simplifying installa-

tion as the dual frequency ADCP can be installed in a single location on, for example, a ship's hull.

While the above detailed description has shown, described, and pointed out novel features of the invention as applied to various embodiments, it will be understood that various omissions, substitutions, and changes in the form and details of the device or process illustrated may be made by those skilled in the art without departing from the invention. The foregoing description is of the best mode presently contemplated of carrying out the invention. This description is in no way meant to be limiting, but rather should be taken as illustrative of the general principles of the invention. The scope of the invention should be determined with reference to the claims.

What is claimed is:

1. A multi-frequency transducer array system, the system comprising:

a single planar surface, comprising:

a first transducer array comprising a first plurality of transducer elements configured to operate at least at a first nominal frequency; and

a second transducer array comprising a second plurality of transducer elements configured to operate at least at a second nominal frequency, the second nominal frequency differing from the first nominal frequency; wherein the first transducer array comprises a central portion that is surrounded by the first plurality of transducer elements, the central portion being devoid of any of the first plurality of transducer elements; and

beamformer circuitry that is electrically coupled with the first transducer array and the second transducer array, the beamformer circuitry configured to provide at least one of time delay or phase delay to signals that are utilized to generate acoustic beams.

2. The system of claim 1, wherein the first plurality of transducer elements are coupled with one another along a first plurality of connections that are oriented in a first direction and along a second plurality of connections that are oriented in a second direction, the first direction differing from the second direction.

3. The system of claim 2, wherein the second plurality of transducer elements are coupled with one another along a third plurality of connections that are oriented in a third direction and along a fourth plurality of connections that are oriented in a fourth direction, the third direction differing from the fourth direction.

4. The system of claim 3, wherein the first direction is orthogonal with the second direction and the third direction is orthogonal with the fourth direction.

5. The system of claim 4, wherein each of the first plurality of connections, the second plurality of connections, the third plurality of connections, and the fourth plurality of connections are electrically coupled with the beamformer circuitry.

6. The system of claim 5, wherein the first transducer array comprises a partially filled array structure, the partially filled array structure comprising a beamwidth of approximately ninety-three percent (93%) of a similarly sized fully filled array structure.

7. The system of claim 1, wherein each of the first plurality of transducer elements comprises a width dimension that is approximately equal to half of an acoustic wavelength for a medium in which the system operates.

9

8. The system of claim 7, wherein each of the first plurality of transducer elements are separated from an adjacent transducer element by the half of the acoustic wavelength.

9. The system of claim 8, wherein each of the second plurality of transducer elements comprises a width dimension that is approximately equal to a quarter of the acoustic wavelength for the medium in which the system operates.

10. The system of claim 9, wherein each of the second plurality of transducer elements are separated from an adjacent array element by the quarter of the acoustic wavelength.

11. A multi-frequency transducer array system, the system comprising:

a single two-dimensional planar transducer array structure comprised of a plurality of individual array elements, each of the individual array elements either being electrically interconnected with at least a portion of other ones of the individual array elements along a plurality of planar front-side columns or a plurality of planar back-side rows, the single transducer array structure comprising:

a first transducer array optimized for operation at a first depth and having a first portion of array elements of the plurality of individual array elements, the first portion of array elements having a first size; and

a second transducer array optimized for operation at a second depth and having a second portion of array elements of the plurality of individual array elements, the second portion of array elements having a second size that differs from the first size, the second depth being different than the first depth;

wherein the first transducer array comprises a fully filled array structure while the second transducer array comprises a partially filled array structure having a center portion that does not include any of the second portion of array elements, the first transducer array being disposed within the center portion; and

beamformer circuitry that is electrically coupled with the plurality of planar front-side columns and the plurality of planar back-side rows, the beamformer circuitry configured to project acoustic beams from both the first transducer array and the second transducer array.

12. The system of claim 11, wherein the single flat two-dimensional planar transducer array structure comprises a symmetric geometrical shape.

10

13. The system of claim 12, wherein the symmetric geometrical shape comprises an ellipse shape, the ellipse shape characterized by a width dimension that differs from a height dimension.

14. The system of claim 12, wherein the symmetric geometrical shape comprises a polygon-based shape.

15. The system of claim 12, wherein each of the first portion of array elements comprises a width dimension that is approximately equal to half of an acoustic wavelength for a medium in which the system operates.

16. The system of claim 15, wherein each of the first portion of array elements are separated from an adjacent array element by the half of the acoustic wavelength.

17. The system of claim 16, wherein each of the second portion of array elements comprises a width dimension that is approximately equal to a quarter of the acoustic wavelength for the medium in which the system operates.

18. The system of claim 17, wherein each of the second portion of array elements are separated from an adjacent array element by the quarter of the acoustic wavelength; and wherein the beamformer circuitry is configured to provide at least one of time delay or phase delay to signals that are configured to project the acoustic beams.

19. The system of claim 11, wherein the partially filled array structure comprises a beamwidth of approximately ninety-three percent (93%) of a similarly sized fully filled array structure.

20. A transducer array, comprising:

a singular planar structure comprising first and second pluralities of electrically independent two-dimensional planar transducers, the first plurality of electrically and acoustically independent two dimensional planar transducers being disposed on a first portion of the singular planar structure, and the second plurality of electrically and acoustically independent two dimensional planar transducers being disposed on a second portion of the singular planar structure, the second portion not overlapping with the first portion; and

wherein the singular planar structure is configured to simultaneously or sequentially form at least first and second acoustic beams at first and second acoustic frequencies, respectively, using respective ones of the first and second pluralities of electrically independent two-dimensional planar transducers.

\* \* \* \* \*