

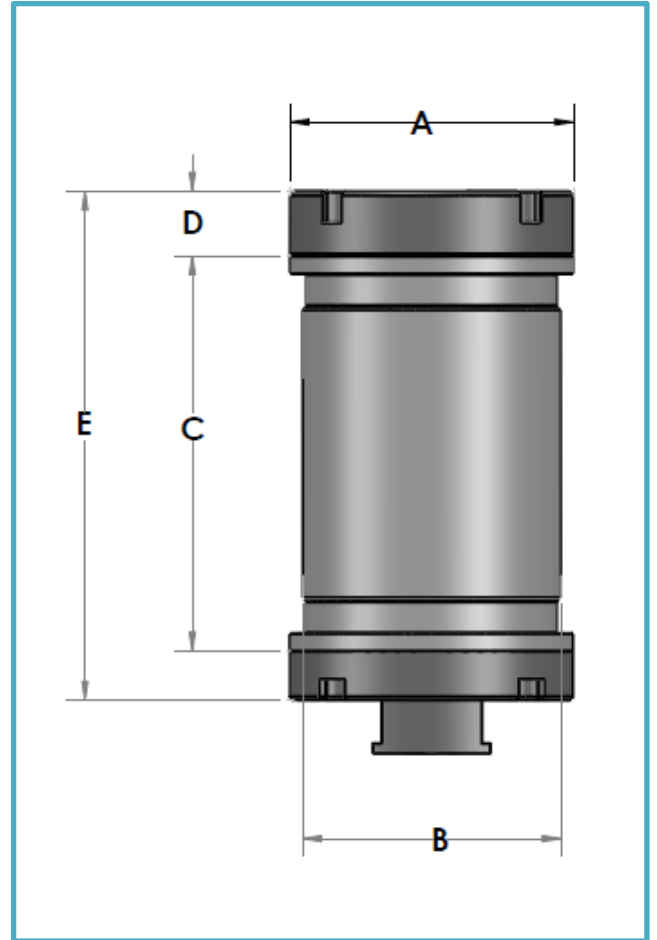

DESCRIPTION: OUTLINE DRAWING OF 75 kHz SYSTEM and Details of External battery pack

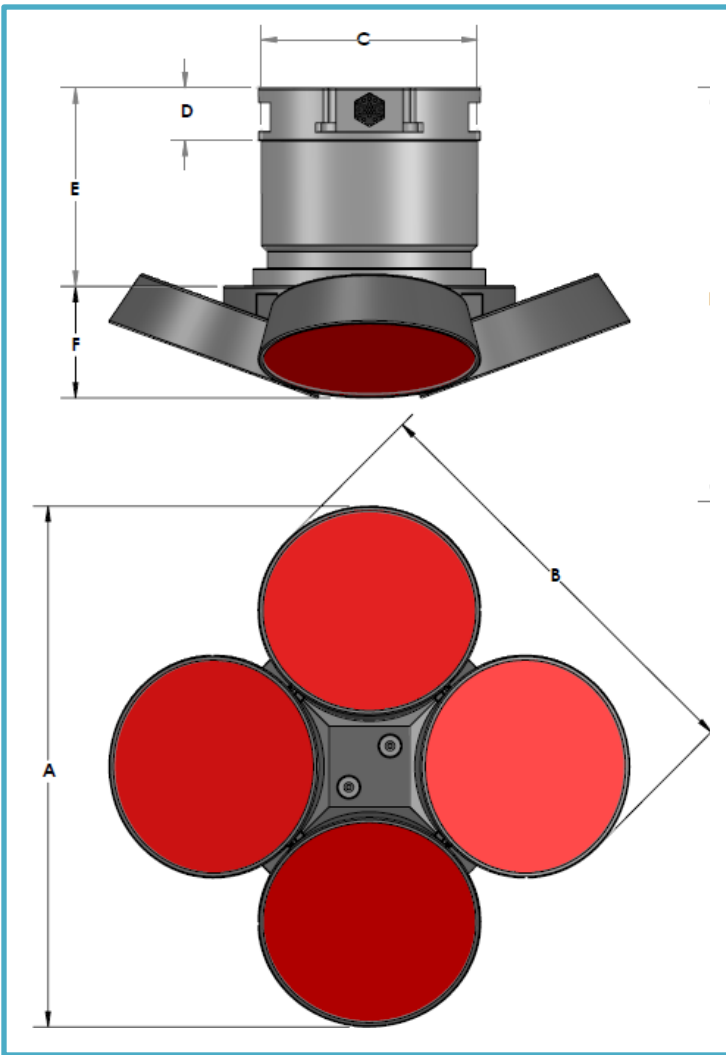

Face view and side view
Single frequency system operating at 75 kHz.
Dual frequency system operating at 75/300 kHz.

Side view of the External battery pack. Table of Mechanical Dimensions are given below.



DESCRIPTION: OUTLINE DRAWING OF 75 kHz SYSTEM and Details of External battery pack

75 kHz DIRECT READ SYSTEM

PRESSURE RATING	HEAD DIAMETER (A)	HEAD WITH SQ (B)	HOUSING DR CENTER DIAMETER (C)	HOUSING FLANGE HEIGHT (D)	HOUSING DR TOTAL HEIGHT (E)	HEAD TOTAL HEIGHT (F)
300 m						
3000 m	25.35"/644mm	21.60"/549mm	7.40"/188mm	1.80"/46mm	11.50"/292mm	6.80"/173mm

75 kHz BATTERY PACK OPTIONS

PRESSURE RATING	END CAP DIAMETER (A)	HOUSING CENTER DIAMETER (B)	BATTERY PACK HOUSING HEIGHT (C)	BATTERY PACK END CAP DIAMETER (D)	BATTERY PACK TOTAL HEIGHT (E)
3000m					
1 BATTERY PACK	7.90"/201mm	7.40"/188mm	6.50"/165mm	1.80"/46mm	9.65"/245mm
2 BATTERY PACKS	7.90"/201mm	7.40"/188mm	11.00"/279mm	1.80"/46mm	14.15"/359mm
4 BATTERY PACKS	7.90"/201mm	7.40"/188mm	21.00"/533mm	1.80"/46mm	24.15"/613mm

Note: 3000 m pressure rated system operating in dual frequency is under development.

This document contains proprietary information of Rowe Technologies Inc. and shall not be used, reproduced, or disclosed to any other parties for any other purpose without the expressed written permission of Rowe Technologies Inc.